

## Operating Instructions

LCD Monitor **Commercial Use**

Model No. **BT-4LH310P**

Model No. **BT-4LH310E**

**4K**  
PROFESSIONAL

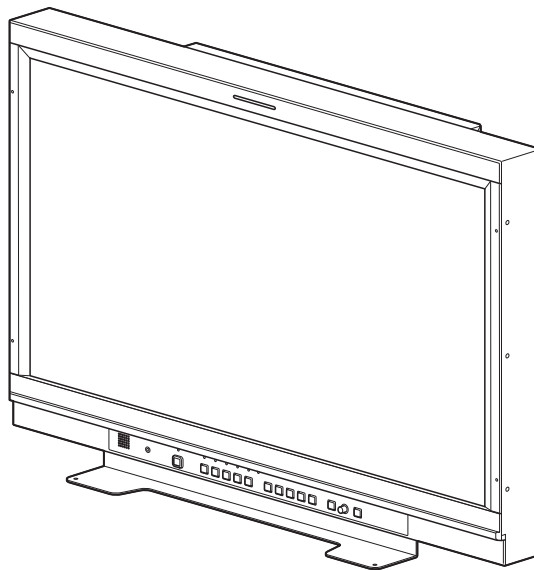

**DEUTSCH**

Für Erläuterungen in Deutsch, konsultieren Sie bitte die mitgelieferte CD-ROM.  
(Zurück Decke)

**FRANÇAIS**

Pour des explications en français, veuillez vous reporter au CD-ROM fourni.  
(Quatrième de couverture)

**ITALIANO**

Per le istruzioni in italiano, vedere il CD-ROM in dotazione. (Retro della copertina)

**ESPAÑOL**

Para la explicación en español, consulte el CD-ROM suministrado. (Cubierta trasera)

This manual is also contained as a PDF file on the CD-ROM supplied with the unit. (Back cover)

Before operating this product, please read the instructions carefully and save this manual for future use.

**ENGLISH**

TQBJ0664

# Read this first ! (for BT-4LH310P)



**CAUTION:** TO REDUCE THE RISK OF ELECTRIC SHOCK, DO NOT REMOVE COVER (OR BACK). NO USER-SERVICEABLE PARTS INSIDE. REFER SERVICING TO QUALIFIED SERVICE PERSONNEL.



The lightning flash with arrowhead symbol, within an equilateral triangle, is intended to alert the user to the presence of uninsulated "dangerous voltage" within the product's enclosure that may be of sufficient magnitude to constitute a risk of electric shock to persons.



The exclamation point within an equilateral triangle is intended to alert the user to the presence of important operating and maintenance (servicing) instructions in the literature accompanying the appliance.

## **WARNING:**

This equipment must be grounded. To ensure safe operation, the three-pin plug must be inserted only into a standard three-pin power outlet which is effectively grounded through normal household wiring. Extension cords used with the equipment must have three cores and be correctly wired to provide connection to the ground. Wrongly wired extension cords are a major cause of fatalities. The fact that the equipment operates satisfactorily does not imply that the power outlet is grounded or that the installation is completely safe. For your safety, if you are in any doubt about the effective grounding of the power outlet, please consult a qualified electrician.

## **WARNING:**

- To reduce the risk of fire or electric shock, do not expose this equipment to rain or moisture.
- To reduce the risk of fire or electric shock hazard, keep this equipment away from all liquids. Use and store only in locations which are not exposed to the risk of dripping or splashing liquids, and do not place any liquid containers on top of the equipment.

## **WARNING:**

Always keep the stand screws and protective panel mounting screws out of the reach of infants and small children.

## **CAUTION:**

The mains plug of the power supply cord shall remain readily operable. The AC receptacle (mains socket outlet) shall be installed near the equipment and shall be easily accessible. To completely disconnect this equipment from the AC mains, disconnect the power cable plug from the AC receptacle.

## **CAUTION:**

In order to maintain adequate ventilation, do not install or place this unit in a bookcase, built-in cabinet or any other confined space. To prevent risk of electric shock or fire hazard due to overheating, ensure that curtains and any other materials do not obstruct the ventilation.

## **CAUTION:**

To reduce the risk of fire or electric shock and annoying interference, use the recommended accessories only.

## **CAUTION:**

This apparatus can be operated at a voltage in the range of 100 - 240 V AC. Voltages other than 120 V are not intended for U.S.A. and Canada.

## **CAUTION:**

Do not use DC power supply whose capacity exceeds 240VA.

## **CAUTION:**

Excessive sound pressure from earphones and headphones can cause hearing loss.

## **CAUTION:**

Check the installation at least once a year. An improper installation could cause the monitor to fall off resulting in personal injury.

 indicates safety information.

## **Notice (U.S.A. only):**

Disposal may be regulated in your community due to Environmental considerations. For disposal or recycling information, please visit Panasonic website: <http://www.panasonic.com/environmental> or call 1-888-769-0149.

## **WARNING (USA and Canada)**

- Not for use in a computer room as defined in the Standard for the Protection of Electronic Computer/Data Processing Equipment, ANSI/NFPA 75.

**FCC NOTICE (USA)**

This device complies with part 15 of the FCC Rules. Operation is subject to the following two conditions:  
(1) This device may not cause harmful interference, and (2) this device must accept any interference received, including interference that may cause undesired operation

**CAUTION:**

This equipment has been tested and found to comply with the limits for a class A digital device, pursuant to Part 15 of the FCC Rules. These limits are designed to provide reasonable protection against harmful interference when the equipment is operated in a commercial environment. This equipment generates, uses, and can radiate radio frequency energy and, if not installed and used in accordance with the instruction manual, may cause harmful interference to radio communications. Operation of this equipment in a residential area is likely to cause harmful interference in which case the user will be required to correct the interference at his own expense.

**Warning:**

To assure continued FCC emission limit compliance, the user must use only shielded interface cables when connecting to external units. Also, any unauthorized changes or modifications to this equipment could void the user's authority to operate it.

 indicates safety information.

# Read this first ! (for BT-4LH310E)

## WARNING:

This equipment must be earthed.  
To ensure safe operation, the three-pin plug must be inserted only into a standard three-pin power point which is effectively earthed through normal household wiring. Extension cords used with the equipment must have three cores and be correctly wired to provide connection to the earth. Wrongly wired extension cords are a major cause of fatalities. The fact that the equipment operates satisfactorily does not imply that the power point is earthed or that the installation is completely safe. For your safety, if you are in any doubt about the effective earthing of the power point, please consult a qualified electrician.

## WARNING:

- To reduce the risk of fire or electric shock, do not expose this equipment to rain or moisture.
- To reduce the risk of fire or electric shock hazard, keep this equipment away from all liquids. Use and store only in locations which are not exposed to the risk of dripping or splashing liquids, and do not place any liquid containers on top of the equipment.

## WARNING:

Always keep the stand screws and protective panel mounting screws out of the reach of infants and small children.

## CAUTION:

Do not remove panel covers by unscrewing them.  
To reduce the risk of electric shock, do not remove covers.  
No user serviceable parts inside.  
Refer servicing to qualified service personnel.

## CAUTION:

The mains plug of the power supply cord shall remain readily operable.  
The AC receptacle (mains socket outlet) shall be installed near the equipment and shall be easily accessible. To completely disconnect this equipment from the AC mains, disconnect the power cable plug from the AC receptacle.

## CAUTION:

To reduce the risk of fire or electric shock and annoying interference, use the recommended accessories only.

## CAUTION:

In order to maintain adequate ventilation, do not install or place this unit in a bookcase, built-in cabinet or any other confined space. To prevent risk of electric shock or fire hazard due to overheating, ensure that curtains and any other materials do not obstruct the ventilation.

## CAUTION:

Do not use DC power supply whose capacity exceeds 240VA.

## CAUTION:

Excessive sound pressure from earphones and headphones can cause hearing loss.

## CAUTION:

Check the installation at least once a year.  
An improper installation could cause the monitor to fall off resulting in personal injury.

 indicates safety information.

**EEE Yönetmeliğine Uygundur.**  
**EEE Complies with Directive of Turkey.**

## [ India Only ]



For the purpose of recycling to facilitate effective utilization of resources, please return this product to a nearby authorized collection center, registered dismantler or recycler, or Panasonic service center when disposing of this product.

Please see the Panasonic website for further information on collection centers, etc.

<http://www.panasonic.co.in/wps/portal/home>

## Caution for AC Mains Lead

### FOR YOUR SAFETY PLEASE READ THE FOLLOWING TEXT CAREFULLY.

This product is equipped with 2 types of AC mains cable. One is for continental Europe, etc. and the other one is only for U.K.

Appropriate mains cable must be used in each local area, since the other type of mains cable is not suitable.

#### FOR CONTINENTAL EUROPE, ETC.

Not to be used in the U.K.

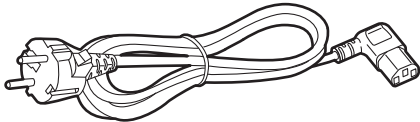

#### FOR U.K. ONLY

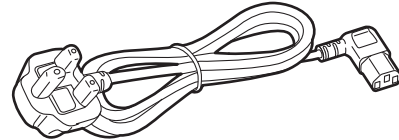

#### FOR U.K. ONLY

This appliance is supplied with a moulded three pin mains plug for your safety and convenience.

A 13 amp fuse is fitted in this plug.

Should the fuse need to be replaced please ensure that the replacement fuse has a rating of 13 amps and that it is approved by ASTA or BSI to BS1362.

Check for the ASTA mark  or the BSI mark  on the body of the fuse.

If the plug contains a removable fuse cover you must ensure that it is refitted when the fuse is replaced.

If you lose the fuse cover the plug must not be used until a replacement cover is obtained.

A replacement fuse cover can be purchased from your local Panasonic Dealer.

#### How to replace the fuse

1. Open the fuse compartment with a screwdriver.

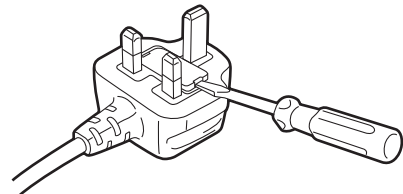

2. Replace the fuse.

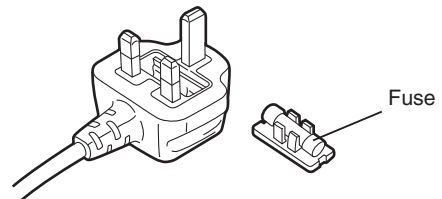

 indicates safety information.

### Note regarding the Power Management function specified under COMMISSION REGULATION (EC) No 1275/2008 implementing Directive 2009/125/EC of the European Parliament and of the Council.

This device is designed and manufactured for use at a broadcasting station and/or in a similar environment.

This device is not equipped with a Power Management function or the Power Management function is set to OFF as it will prevent the device from fulfilling its intended purpose for the reasons below.

1. If the device is a Studio Camera, a Weather Camera, a Mixer or other processor:

A Power Management function may cause the device to suddenly stop during recording or while On Air.

2. If the device is a Studio Monitor:

A Power Management function may cause video for the confirmation of whether a signal is normal, or whether the signal has been lost, to be un-viewable.

3. If the device is a Camera Recorder:

A professional camera recorder must be able to start quickly at any time, but a Power Management function will cause an increase in the time taken to resume from Stand-by mode.

Manufactured by: Panasonic Corporation, Osaka, Japan

Importer's name and address of pursuant to EU rules:

Panasonic Testing Centre

Panasonic Marketing Europe GmbH

Winsbergring 15, 22525 Hamburg, Germany

**Read this first ! (for BT-4LH310E) (Continued)**

Declaration of Conformity

with the requirements of Technical Regulation on the Restriction Of the use of certain Hazardous Substances in Electrical and Electronic Equipment

(adopted by Order №1057 of Cabinet of Ministers of Ukraine)

The Product is in conformity with the requirements of Technical Regulation on the Restriction Of the use of certain Hazardous Substances in electrical and electronic equipment (TR on RoHS).

The content of hazardous substance with the exemption of the applications listed in the Annex №2 of TR on RoHS:

1. Lead (Pb) – not over 0,1 % or 1000wt ppm;
2. Cadmium (Cd) – not over 0,01 % or 100wt ppm;
3. Mercury (Hg) – not over 0,1 % or 1000wt ppm;
4. Hexavalent chromium (Cr6+) – not over 0,1 % or 1000wt ppm;
5. Polybrominated biphenyls (PBBs) – not over 0,1 % or 1000wt ppm;
6. Polybrominated diphenyl ethers (PBDEs) – not over 0,1 % or 1000wt ppm.

Декларація про Відповідність

Вимогам Технічного Регламенту Обмеження Використання деяких Небезпечних Речовин в електричному та електронному обладнанні

(затвердженого Постановою №1057 Кабінету Міністрів України)

Виріб відповідає вимогам Технічного Регламенту Обмеження Використання деяких Небезпечних Речовин в електричному та електронному обладнанні (ТР ОБНР).

Вміст небезпечних речовин у випадках, не обумовлених в Додатку №2 ТР ОБНР, :

1. свинець(Pb) – не перевищує 0,1 % ваги речовини або в концентрації до 1000 частин на мільйон;
2. кадмій (Cd)– не перевищує 0,01 % ваги речовини або в концентрації до 100 частин на мільйон;
3. ртуть(Hg) – не перевищує 0,1 % ваги речовини або в концентрації до 1000 частин на мільйон;
4. шестивалентний хром (Cr6+ ) – не перевищує 0,1 % ваги речовини або в концентрації до 1000 частин на мільйон;
5. полібромбіфеноли (PBB) – не перевищує 0,1% ваги речовини або в концентрації до 1000 частин на мільйон;
6. полібромдефенілові ефіри (PBDE) – не перевищує 0,1 % ваги речовини або в концентрації до 1000 частин на мільйон.

Декларация о Соответствии

Требованиям Технического Регламента об Ограничении Использования некоторых Вредных Веществ в электрическом и электронном оборудовании

(утверждённого Постановлением №1057 Кабинета Министров Украины)

Изделие соответствует требованиям Технического Регламента об Ограничении Использования некоторых Вредных Веществ в электрическом и электронном оборудовании (ТР ОИВВ).

Содержание вредных веществ в случаях, не предусмотренных Дополнением №2 ТР ОИВВ:

1. свинец (Pb) – не превышает 0,1 % веса вещества или в концентрации до 1000 миллионных частей;
2. кадмий (Cd) – не превышает 0,01 % веса вещества или в концентрации до 100 миллионных частей;
3. ртуть (Hg) – не превышает 0,1 % веса вещества или в концентрации до 1000 миллионных частей;
4. шестивалентный хром (Cr6+)– не превышает 0,1 % веса вещества или в концентрации до 1000 миллионных частей;
5. полибромбифенолы (PBB) – не превышает 0,1 % веса вещества или в концентрации до 1000 миллионных частей;
6. полибромдифеноловые эфиры (PBDE) – не превышает 0,1 % веса вещества или в концентрации до 1000 миллионных частей.

# Accessories and Options

---

## ■ Accessories

- Power cable x 1 (BT-4LH310P)
- Power cable x 2 (BT-4LH310E)
- Stand (already attached to the unit) x 1
- Stand mounting screws (already attached to the unit) x 4
- Protective panel mounting screws (M3, 8 mm (5/16") long) x 4
- Use these screws for the permanent attachment of a protective panel designed for the unit. (→page 11)
- Tightening torque: Tighten to about 30 N·cm or less
- CD-ROM x 1

### <Note>

- After unpacking the product, dispose of the AC cord cap(BT-4LH310E) and packaging material in an appropriate manner.
- Store the small parts in an appropriate location that is out of the reach of infants and small children.

## About These Operating Instructions

---

- These operating instructions refer to BT-4LH310P/BT-4LH310E as "this unit."
- The illustrations, explanatory drawings, and other figures included in these operating instructions are for illustrative purposes only and may differ from the actual appearance.
- HDMI, HDMI logo, and High-Definition Multimedia Interface are trademarks or registered trademarks of HDMI Licensing LLC in the United States and/or other countries.
- VESA and DisplayPort are trademarks or registered trademarks of the Video Electronics Standards Association.
- Adobe® Reader® is a trademark of Adobe Systems Incorporated.
- Page references are indicated as (→ page 00) in these operating instructions.

## Transportation precautions

---

Do not try to lift the monitor by grabbing the LCD panel.

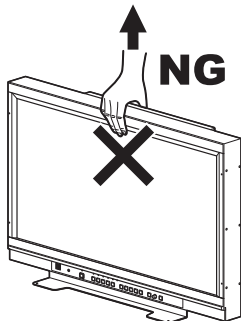

Transport the monitor standing upright and secure it so that it cannot fall over to prevent damaging it.

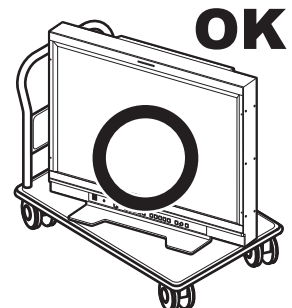

Do not expose the LCD panel to strong pressure or pressure from pointed objects. Take care especially during transportation. Exposing the LCD panel to strong pressure may result in blurring or other damage.

# Table of Contents

---

<b>Read this first ! (for BT-4LH310P)</b> .....	<b>2</b>	<b>User Data</b> .....	<b>22</b>
<b>Read this first ! (for BT-4LH310E)</b> .....	<b>4</b>	Saving User Data .....	22
<b>Accessories and Options</b> .....	<b>7</b>	Loading User Data .....	22
<b>About These Operating Instructions</b> .....	<b>7</b>	<b>Main Menu</b> .....	<b>23</b>
<b>Transportation precautions</b> .....	<b>7</b>	Menu Configuration .....	23
<b>Precautions for Use</b> .....	<b>9</b>	MARKER .....	24
<b>Outline</b> .....	<b>9</b>	MARKER Types .....	27
<b>Dimensions</b> .....	<b>10</b>	VIDEO CONFIG .....	28
<b>Names and Functions of Parts</b> .....	<b>11</b>	MEASURE SETUP .....	30
Video Monitor .....	11	SYSTEM CONFIG .....	31
Front Panel .....	12	Executing AUTO CALIBRATION .....	36
Connector Section (Right Side Panel) .....	13	Executing RESET .....	36
<b>Power supply</b> .....	<b>14</b>	FUNCTION .....	37
Connecting the Power Cable .....	14	AUDIO .....	46
<b>Detaching and Attaching the Stand</b> .....	<b>15</b>	DISPLAY SETUP .....	47
Detaching the Stand .....	15	CONTROL .....	48
Attaching the Stand .....	15	INFORMATION .....	49
<b>On-screen Display</b> .....	<b>16</b>	HOURS METER .....	49
Operating Status Display .....	16	SDI ERROR LOG .....	49
Main Menu (MAIN MENU)/FUNCTION Menu/ INPUT SELECT Menu Display .....	16	<b>Setting Item Restrictions</b> .....	<b>50</b>
Picture Adjustment (PICTURE) Menu Display .....	17	<b>REMOTE Specifications</b> .....	<b>54</b>
Audio Volume Display .....	17	GPI Input Connector .....	54
FUNCTION Display .....	17	RS-232C Input Connector .....	55
Audio Level Meter Display .....	18	RS-485 Input/Output Connectors .....	56
Time Code (TC) Display .....	18	<b>Error and Warning Information</b> .....	<b>63</b>
Closed Caption (CC) Display .....	19	<b>Cleaning</b> .....	<b>63</b>
<b>On-screen Menu Operations</b> .....	<b>20</b>	<b>Specifications</b> .....	<b>64</b>
Main Menu (MAIN MENU) .....	20	<b>Utility Software (Support Coming Soon)</b> .....	<b>72</b>
FUNCTION Menu .....	20	<b>Index</b> .....	<b>74</b>
INPUT SELECT Menu .....	20		
Picture Adjustment (PICTURE) Menu .....	21		
Audio Volume .....	21		



# Precautions for Use

---

- The LCD monitor is manufactured with high-precision technology and has an effective pixel count of 99.99 % or more. However, less than 0.01 % of pixels may be stuck or dead. This is not a malfunction and does not affect recorded images.
- If a still image is displayed for an extended period of time, it may generate a temporary afterimage (phosphor burn-in). (However, afterimages can be removed by displaying normal video for a while.)
- LCD response speed and brightness vary depending on the ambient temperature.
- Do not install the unit where it will be exposed to direct sunlight. The cabinet may deteriorate and the LCD screen may be damaged.
- Do not install the unit in locations where enough space cannot be provided around it as heat may build up inside, preventing normal operation. Be sure to provide at least 80 mm (3-1/8") of space from the rear of the unit.
- Exposing the LCD screen to intense light sources will impair its characteristics and lower image quality.
- In an environment exposed to drastic temperature fluctuations, condensation may build up on and inside the LCD screen. This may lower the quality of the screen and cause a malfunction.
- There may be some unevenness on the screen depending on the image displayed.
- Leaving the unit in a location exposed to high temperature and humidity for an extended period of time may impair the characteristics of the LCD screen and cause unevenness.
- Streaks of light may be seen in the area between the edge of the screen and the frame but this is normal and not a malfunction.
- Protective material is attached to the front to protect the LCD panel from damage during removal from the packing box and transportation. Remove it before use.
- This unit does not support VIERA Link. If the unit is connected to a VIERA-Link-compatible device with an HDMI cable, the VIERA Link functions of the other device may not operate properly.
- If the unit is used near a wireless transmitter, high-voltage equipment, speaker, large motor, or other device or exposed to static electricity, the audio and video may be distorted by electromagnetic waves.
- Do not install the unit in a location that is 2 000 m (6561' 1/8") or more above sea level. Doing so may affect the lifespan of the parts and result in a malfunction.
- Do not install the unit outdoors. Use the unit indoors.
- For the DisplayPort cables, use DisplayPort cables that comply with the DisplayPort standard. Using a cable that does not comply with the DisplayPort standard may result in incorrect operation such as video being interrupted or not being displayed.
- For the HDMI cables, use HDMI High Speed cables that comply with the HDMI standard. Using a cable that does not comply with the HDMI standard may result in incorrect operation such as video being interrupted or not being displayed.

## Outline

---

The unit is an LCD monitor for industrial applications, equipped with a 78.9 cm (31.1") (effective display area) LCD.

### ■ High-performance LCD panel

- The unit incorporates a full 4K (4096 x 2160) LCD panel.
- It offers excellent color reproduction, a wide viewing angle, and a fast response time.

### ■ High resolution and high image quality technology

- The implementation of 10-bit for all signal circuit processing as well as 3D look up table (LUT) image processing facilitates accurate and smooth gradation from low to high brightness levels.
- Support for digital cinema DCI (P3)\*1 in addition to color space (SMPTE-C/EBU/ITU-709) allows you to also use the unit for cinema production applications.
- Gamma compensation is performed for each monitor.

\*1 u' v' coverage: 96 %

### ■ Wide variety of functions and interfaces

- The unit is equipped with four 3G/HD-SDI lines, two HDMI lines, and two DisplayPort lines.
- FOCUS-IN-RED function  
Focusing the camera is extremely easy because the area of the image in focus is displayed in red or another color to make it easy to see what is in focus.
- LUT upload function  
Color conversion data generated by a color grading device or other device can be imported to the unit to enable the reproduction of the colors intended by your colorist.
- 4-screen display function (3G/HD-SDI inputs and same format)
  - The panel display area can be split into four to display four input signals independently.
  - The time code and audio level meter superimposed on each input signal can be displayed independently.

- Camera adjustments can be simplified by simultaneously displaying FOCUS-IN-RED, WFM, and vectorscope based on one input signal. (MULTI FUNCTION)
- One input signal can be displayed on four screens and you can independently change the gamma, color temperature, and color gamut or adjust the image quality on three of the screens. This function facilitates easy comparison with the original image to check the differences created by effects. (PICTURE ASSIST)
- Audio level meter display function  
This function allows you to display the level of an audio signal embedded in a 3G/HD-SDI, HDMI, or DisplayPort signal. Furthermore, support is also included for reference point setting, peak hold, and overrange display.  
The unit is equipped with a speaker and HEADPHONES output jack so you can check the audio. There is also a menu for selecting channels.
- Cross hatch display function  
This function displays markers at regular vertical and horizontal intervals to facilitate easy composition.
- External remote control  
The unit is equipped with RS-485, RS-232C, and GPI remote control connectors. A daisy chain connection using the RS-485 input/output connectors enables the control of multiple monitors (up to 32 monitors).
- A robust metal frame has been employed to ensure the durability required for transportation.
- Support for DC driving means you can also operate the unit on batteries.

# Dimensions

Unit: mm

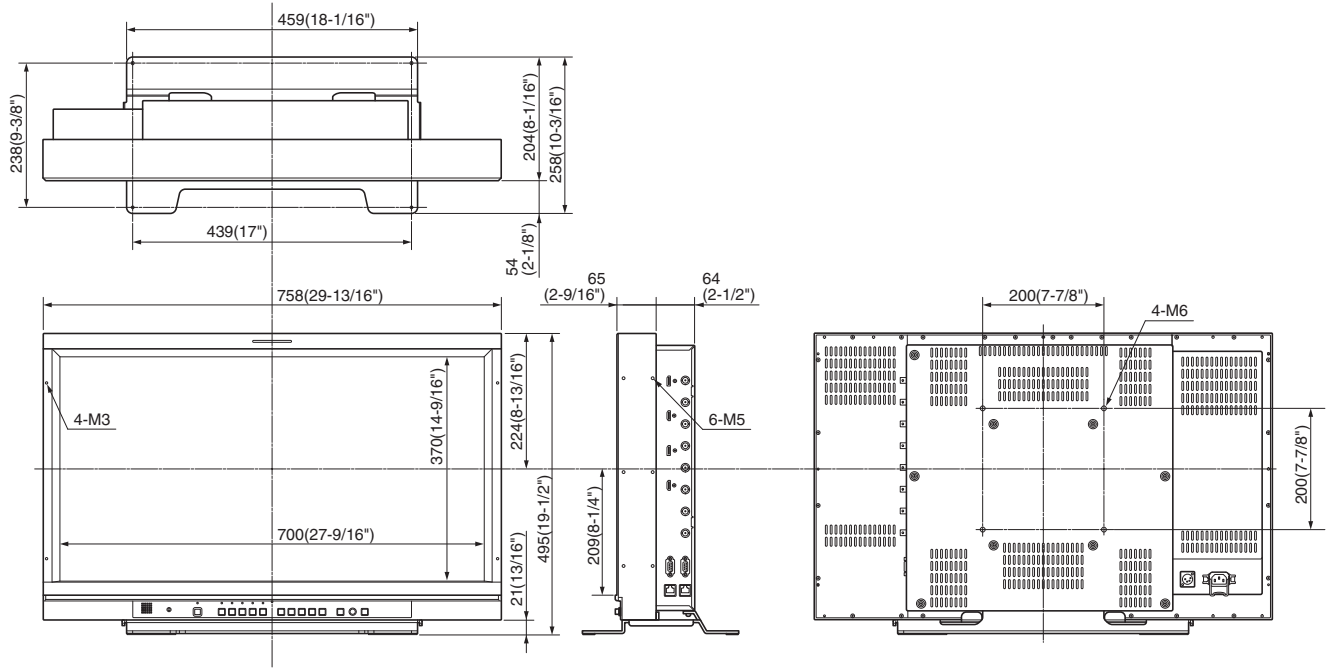

# Names and Functions of Parts

## Video Monitor

Front

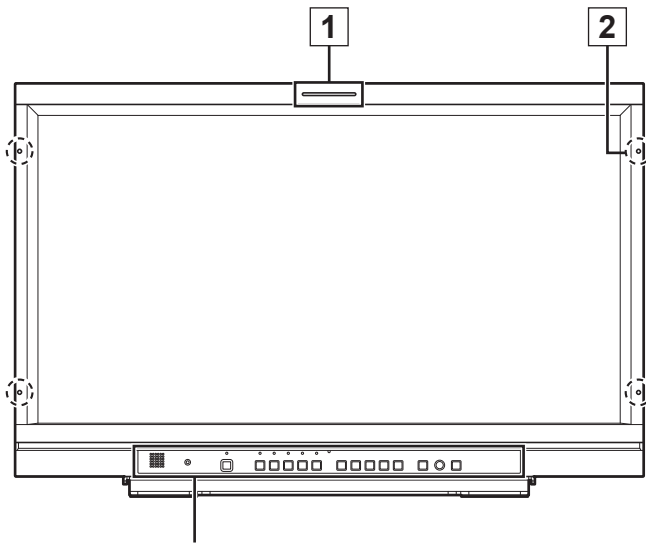

Front Panel  
(→page 12)

Rear

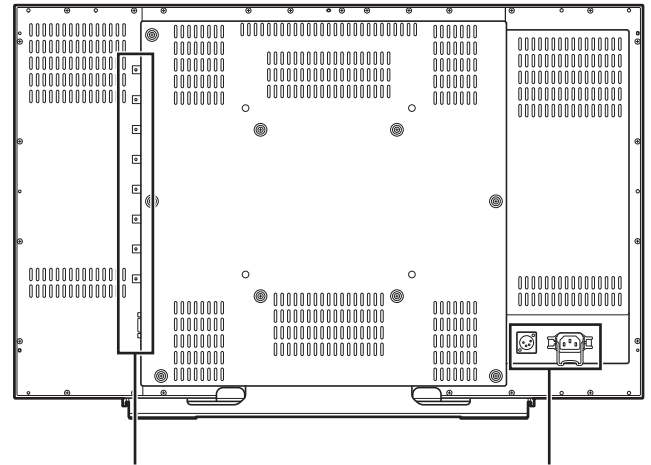

Connector Section  
(Right Side Panel)  
(→page 13)

Connecting the  
Power Cable  
(→page 14)

### 1 Tally lamps (red and green)

The red tally and green tally can be lit by a control signal from GPI.

When both the red tally and green tally light at the same time, the tally color will be amber.

The red tally can be made to light when the REC status information is superimposed on the SDI signal. (→SDI REC TALLY on page 32)

### 2 Protective panel mounting screw holes (4 holes)

Four screw holes have been provided to enable attachment of a permanent protective panel.

Be sure to use the supplied protective panel mounting screws (M3, 8 mm long).

#### <Note>

Protective material is attached at the time of shipment to protect the LCD panel from damage during removal from the packing box and transportation. Remove it before using the unit.

## Front Panel

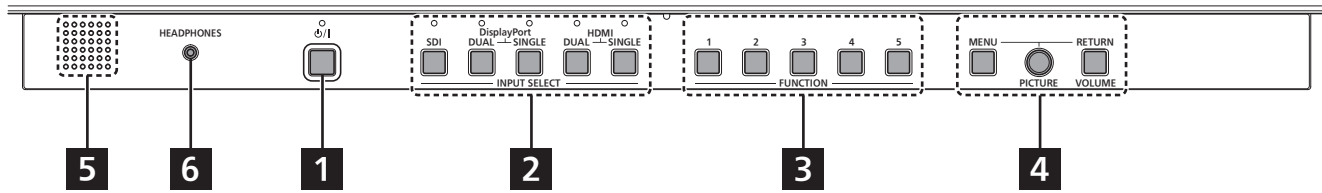

### 1 POWER <⏻/▶> switch

Switches the power on/off. When the power is turned on, the green lamp lights.  
To turn the power off, press and hold the switch for at least three seconds.

### 2 INPUT SELECT buttons

Selects the signal input line. The green lamp above the pressed button indicates the selected input line.

SDI: Serial digital interface input (3G/HD compatible)

DisplayPort DUAL: DisplayPort input (HDCP compatible)

DisplayPort SINGLE: DisplayPort input (HDCP compatible)

HDMI DUAL: HDMI input (HDCP compatible)

HDMI SINGLE: HDMI input (HDCP compatible)

- When the power is turned on, the input line becomes the one selected when the power was last turned off.
- When the FORMAT setting is set to AUTO, both the DUAL and SINGLE LED indicators are lit when DisplayPort or HDMI input is detected.  
When it is set to 2K/HD/PC, the selection becomes SDI/DisplayPort SINGLE/HDMI SINGLE.
- When the control lock is on, the  mark is displayed on the screen and the input line cannot be changed. (→page 48)
- When INT-SG (internal chart for adjustment [Color Bar + Grayscale]) is selected, all the lamps above the <INPUT SELECT> buttons are off. Use the [INPUT SELECT] menu to select INT-SG. (→page 20)

### 3 FUNCTION buttons

FUNCTION1 to Function5:  
Press a FUNCTION button to execute the function selected for that button in the menu.

- When the control lock is on, the  mark is displayed on the screen and the FUNCTION operation is disabled. (→page 48)

### 4 MENU button, rotary knob (with PICTURE push-on switch), and RETURN/VOLUME button (→page 16)

Use these to display menus, select and adjust settings, and execute items selected in a menu.

MENU: Displays [TOP MENU] ([MAIN MENU] (main menu), [FUNCTION] menu, or [INPUT SELECT] menu). Also press this to exit a menu.

Rotary knob: Turn the knob clockwise or counterclockwise to move the cursor up or down or change a setting value.

Press the knob to start changing or confirm a setting value or display a submenu.

RETURN: Press this button to display the previous menu or return the setting being set to the original value.

When no menu is displayed, pressing the rotary knob <PICTURE> or <RETURN/VOLUME> button displays a menu other than the [TOP MENU].

PICTURE: When no menu is displayed, pressing the rotary knob displays the [PICTURE] (picture adjustment) menu. (→page 17)

VOLUME: When no menu is displayed, pressing the <RETURN/VOLUME> button displays the audio volume bar meter. (→page 17)

### 5 Speaker (monaural)\*1

This allows you to check the audio.

- Audio is not output while headphones are connected to the HEADPHONES output connector.

### 6 HEADPHONES output connector (M3 stereo mini jack)\*1

Headphones can be connected to check the audio.

- The volume and sound quality differ depending on the headphones.

\*1 For an 4K signal (SDI [QUAD], DisplayPort [DUAL], or HDMI [DUAL]), you can check the audio of the input signal set in the 4K INPUT SELECT item of the AUDIO menu for the corresponding connector.

#### <Note>

The brightness of the front LEDs can be changed in the [LED BRIGHT] setting (→page 33). However, the brightness will always be in HIGH mode immediately after startup.

Connector Section (Right Side Panel)

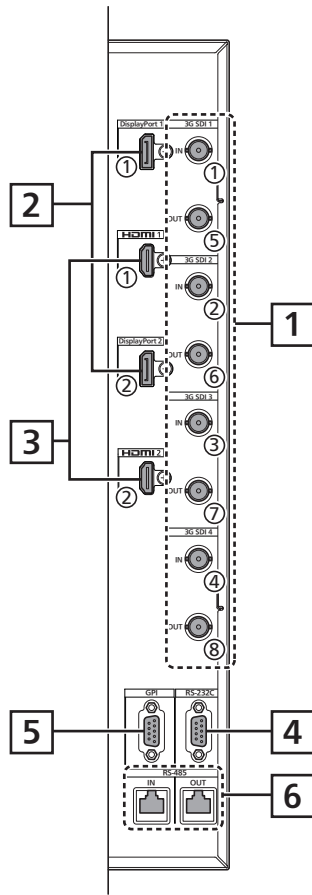

**1 SDI connectors**

- ① SDI1 (3G/HD) input connector (BNC)  
This is an SDI input connector. (It is compatible with 3G-SDI and 3G/HD automatic switching.)
- ② SDI2 (3G/HD) input connector (BNC)  
This is an SDI input connector. (It is compatible with 3G-SDI and 3G/HD automatic switching.)
- ③ SDI3 (3G/HD) input connector (BNC)  
This is an SDI input connector. (It is compatible with 3G-SDI and 3G/HD automatic switching.)
- ④ SDI4 (3G/HD) input connector (BNC)  
This is an SDI input connector. (It is compatible with 3G-SDI and 3G/HD automatic switching.)
- ⑤ SDI1 active through output connector (BNC)  
This connector outputs SDI1 input as is.  
• The SD-SDI signal is not displayed but it is output.
- ⑥ SDI2 active through output connector (BNC)  
This connector outputs SDI2 input as is.  
• The SD-SDI signal is not displayed but it is output.
- ⑦ SDI3 active through output connector (BNC)  
This connector outputs SDI3 input as is.  
• The SD-SDI signal is not displayed but it is output.
- ⑧ SDI4 active through output connector (BNC)  
This connector outputs SDI4 input as is.  
• The SD-SDI signal is not displayed but it is output.

- When this unit is used to connect multiple monitors in a daisy-chain\*1, the screen may become distorted or noise may occur depending on factors such as the quality of the original signal, cable length, and number of connected devices.

\*1 **Daisy-chain:**

This is a method to connect one signal to multiple devices in sequence by connecting the through-out of a signal connected to an input connector of a device to a second connector of this unit or to an input connector of a second device, and connecting that through-out to a third connector of this unit or an input connector of a third device, and so on.

- Use a 5CFB or equivalent cable to connect to an SDI connector.

**2 DisplayPort connectors**

- ① DisplayPort1 signal input connector  
Use a double shielded cable to connect to a DisplayPort connector.
- ② DisplayPort2 signal input connector  
Use a double shielded cable to connect to a DisplayPort connector.

**3 HDMI connectors**

- ① HDMI1 signal input connector  
Use a double shielded cable to connect to an HDMI connector.
- ② HDMI2 signal input connector  
Use a double shielded cable to connect to an HDMI connector.

**4 RS-232C input connector (D-SUB, 9-pin)**

External control is possible with an RS-232C signal.

- Use a shielded cable to connect to the RS-232C input connector.

**5 GPI input connector (D-SUB, 9-pin)**

External control is possible with a GPI signal.

- Use a shielded cable to connect to the GPI input connector.

**6 RS-485 input/output connectors (RJ-45)**

External control is possible with an RS-485 signal.

- Use a shielded cable to connect to an RS-485 input/output connector.
- Make sure that the cable plug is fully inserted in the connector and cannot easily be pulled out.
- A daisy chain connection using the RS-485 input/output connectors enables the control of multiple monitors (up to 32 monitors).
- Connect a terminator (120 Ω) between the first and second pin of the RS-485 OUT terminal on the last monitor in the chain.

# Power supply

## Connecting the Power Cable

### 1. Connect the power cable to the unit.

- Attach the hook to the plug to prevent it from becoming disconnected in the event of the power cord being pulled.

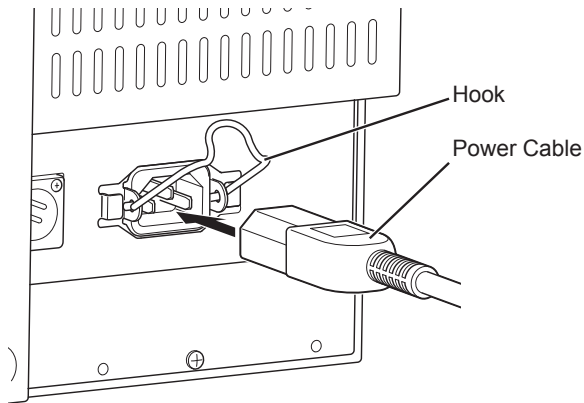

### 2. Connect the power cable to the power outlet.

### ■ When using an external DC power supply (28 VDC)

- Insert the plug all the way in to prevent it from becoming disconnected in the event of the DC cord being pulled.

#### <Note>

Use a shielded DC cord that is shorter than 2 m (6' 7"). Using a DC cord that is 2 m (6' 7") or longer may cause noise to be generated on the screen.

When using an external DC power supply, be sure to check the external DC power supply ratings and use one that is suitable for the unit. Check the pin assignment of the DC output connector of the external DC power supply and the DC IN connector on the unit, and connect the connectors with the correct polarity. Accidentally connecting a +28 V power supply to the GND connector may cause a fire or injury.

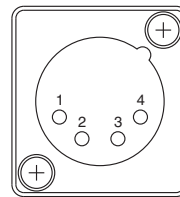

External DC input connector

Pin number	Signal
1	GND
2	—
3	—
4	+28 V

# Detaching and Attaching the Stand

The stand is detachable.

- When detaching and attaching the stand, it is recommended that you place the unit flat on the edge of a desk or table with a soft cloth or similar material spread underneath.
- The stand is specifically designed for this monitor and cannot be used with other monitors.

## Detaching the Stand

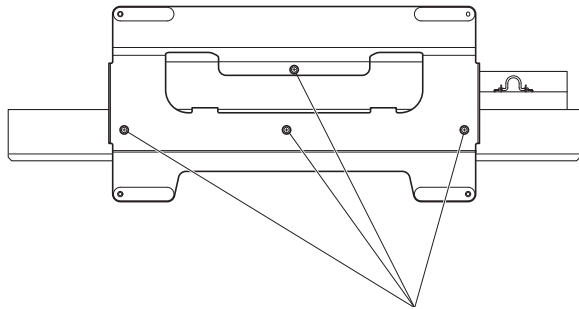

Stand mounting screws

**Remove the stand mounting screws (four) using a Phillips screwdriver.**

- Store the detached stand and stand mounting screws in a safe place for future use.

## Attaching the Stand

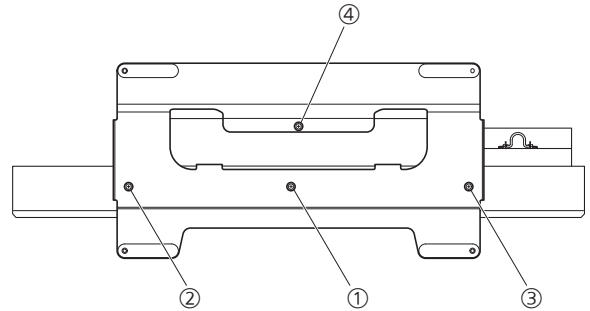

**1. Align the holes in the stand with those in the monitor.**

**2. Use a Phillips screwdriver to secure the stand to the unit with the stand mounting screws (four).**

- Install the mounting screws in the order (① to ④) shown in the figure.
- When attaching the stand, tighten the stand mounting screws to a tightening torque from 80 N·cm to 120 N·cm.

# On-screen Display

The screen shows the operating status display, main menu (MAIN MENU) / FUNCTION menu / INPUT SELECT menu display, picture adjustment (PICTURE) menu display, audio volume display, FUNCTION display, audio level meter display, time code (TC) display, closed caption (CC) display, and other information.

## Operating Status Display

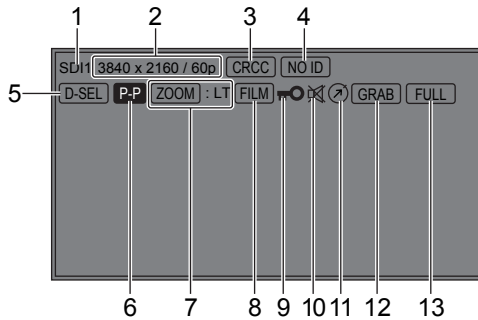

### <Note>

- The status display state can be set in [STATUS DISPLAY] of the [SYSTEM CONFIG] menu. (→page 32)
- Icons meeting the 3 to 8 display conditions are displayed aligned to the left.
- [UNSUPPORT SIGNAL] and [NO SIGNAL] may not be displayed properly.

### 1. Selected input line (→ page 12, 20)

- Displays [SDI1], [SDI2], [SDI3], [SDI4], [DisplayPort1], [DisplayPort2], [HDMI1], [HDMI2], [INT-SG], etc.

### 2. Signal format indication

- If [UNSUPPORT SIGNAL] is displayed, an unsupported signal is being input.  
It may also indicate that the format of the input signal differs from that set in the [INPUT SELECT] menu.
- When [NO SIGNAL] is displayed, a signal is not being input.

### 3. Various indications (CRCC error information)

- Displayed when a CRCC error occurred during SDI input.

### 4. Various indications (payload ID information)

- Displayed when there was an error with the payload ID during SDI input.
- [NOID] is displayed if there is no payload ID and [ID] is displayed if the signal format and payload ID do not match.

### 5. Various indications (screen selection information)

- Displayed when normal mode and PICTURE ASSIST mode of SDI QUAD mode.
- Displayed in the status display section of the area selected in the screen in DISPLAY SELECT.

### 6. Various indications (PIXEL TO PIXEL mode)

- Displayed when image display is PIXEL TO PIXEL.

### 7. Various indications (ZOOM mode)

- Displayed when using the ZOOM function and also includes the ZOOM target position.

### 8. Various indications (FILM mode)

- Displayed when [GAMMA SELECT] in the [VIDEO CONFIG] menu is set to [FILM].

### 9. Various indications (lock setting)

- Displayed when front panel operation is locked. (→page 48)

### 10. Various indications (audio mute indication)

- Displayed when the speaker and headphones are muted. (→page 21)

### 11. Various indications (picture adjustment change indication)

- Indicates that picture adjustments ([PEAKING]/[PHASE]/[CHROMA]/[BRIGHT]/[CONTRAST]/[BACKLIGHT]) have been changed from the values confirmed in [SETUP LOAD] or [POWER ON SETUP]. (→page 21)

### 12. Various indications (FRAME GRAB function)

- Displayed when the FRAME GRAB function is operating and a still image is displayed. (→page 43)

### 13. Various indications (quantization range to apply to input signal)

- Displayed when [RANGE] in the [SYSTEM CONFIG] menu is set to [FULL] or [LIMITED]. (→page 31)

## Main Menu (MAIN MENU)/FUNCTION Menu/INPUT SELECT Menu Display

### 1. Press <MENU> when no menu is displayed.

- [TOP MENU] appears.





## On-screen Display (Continued)

2. Turn the rotary knob <PICTURE> to select a menu ([MAIN MENU], [FUNCTION], or [INPUT SELECT]) and press the rotary knob <PICTURE>.

- For details on how to operate menus, refer to “On-screen Menu Operations” (→ page 20).

[MAIN MENU]

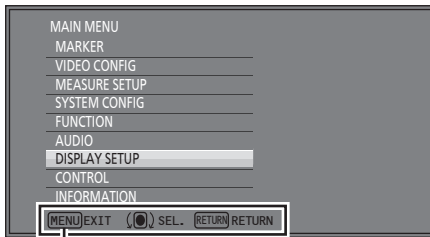

[FUNCTION]

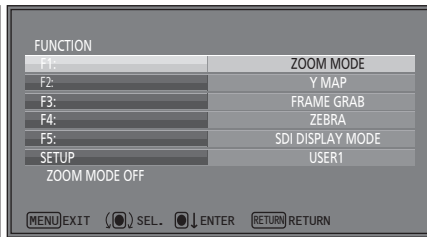

[INPUT SELECT]

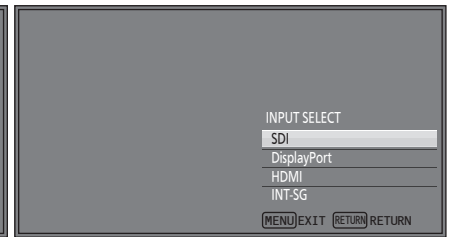

Instructions on <MENU> button operations are displayed.

3. To close a menu, press <MENU>.

- The menu display disappears after approximately 2 minutes of inactivity. (The value shown before the display disappears is confirmed as the setting value.)

## Picture Adjustment (PICTURE) Menu Display

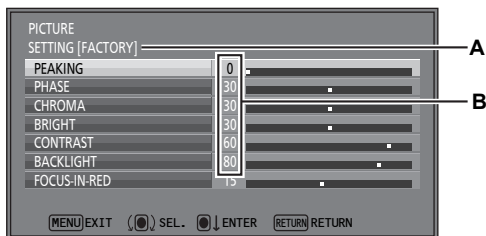

- A: The file name called by [SETUP LOAD] or [POWER ON SETUP] is displayed for [SETTING].
- B: When the picture adjustment values ([PEAKING]/[PHASE]/[CHROMA]/[BRIGHT]/[CONTRAST]/[BACKLIGHT]) are changed from the factory defaults, the position pointers are displayed in white.

1. Press the rotary knob <PICTURE> when no menu is displayed.

- The [PICTURE] (picture adjustment) menu appears.
- For details on how to operate menus, refer to “Picture Adjustment (PICTURE) Menu” (→page 21).

2. To close a menu, press <MENU>.

- This display disappears after approximately 10 seconds of inactivity. (The value shown before the display disappears is confirmed as the setting value.)

## Audio Volume Display



1. Press <RETURN/VOLUME> when no menu is displayed.

- The audio volume bar meter appears.
- For details on how to operate the audio volume, refer to “On-screen Menu Operations” (→ page 20).

2. To close a menu, press <MENU>.

- This display disappears after approximately 10 seconds of inactivity. (The value shown before the display disappears is confirmed as the setting value.)

## FUNCTION Display

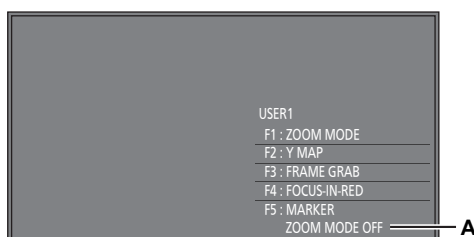

- The display settings can be set from the [FUNCTION] menu.
- When [FUNCTION DISPLAY] (→page 38) is set to [ON1] or [ON2], press any of the <FUNCTION1> to <FUNCTION5> buttons to display the status of the item set for FUNCTION.
- If no operation is performed for approximately 2 seconds, the set value is confirmed and the display disappears.
- “A” indicates the operating status. (→ “Operation items displayed on the screen during FUNCTION button operation” on page 39)
- The items assigned to F1 to F5 can be changed in [SETUP] (→page 38).

**Audio Level Meter Display**

● SINGLE screen

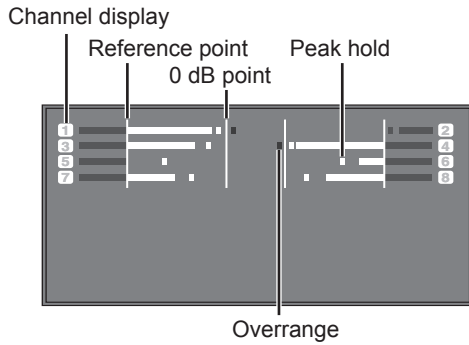

- When SDI, HDMI, and DisplayPort signals are input, a color bar meter indicates the audio level.
- The display method of the audio level meter can be set in the menu. (→page 47)
- In QUAD screen mode, an audio level meter is displayed for each of SDI1, SDI2, SDI3, and SDI4.

**Display color**

- Green: Up to reference point (included)
- Yellow: Reference point (not included) to 0 dB point (not included)
- Red: Overrange

● QUAD screen

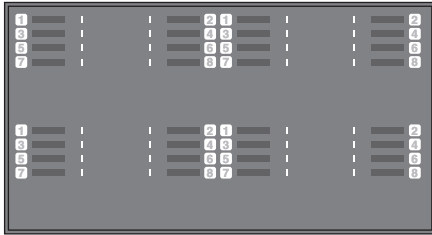

**Time Code (TC) Display**

● SINGLE screen

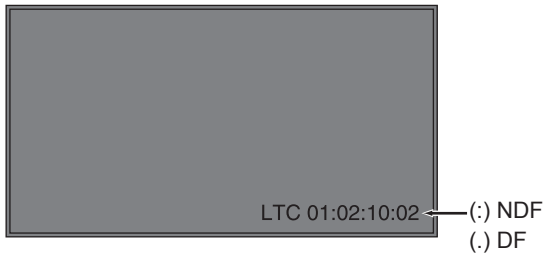

- The display settings can be set in the menu. Also, the display mode ([LTC], [VTC], [LUB], [VUB], [LTC+LUB], or [VTC+VUB]) can be selected in the menu. (→page 47)
- In QUAD screen mode, the TC is displayed for each of SDI1, SDI2, SDI3, and SDI4.

**<Note>**

“VITC” is indicated as “VTC” on this unit.

**In LTC and VTC display mode**

- Displays the time code in the order of hour : minute : second : frame.
- In drop-frame mode, a different delimiter is used between the second and frame indications.

**<Note>**

Read errors are displayed as “--:--:--:--.”

**In LUB and VUB display modes:**

- Displays the time code in the order of BG8, BG7, BG6, BG5, BG4, BG3, BG2, and BG1.  
BG: Binary group
- The colon (:) delimiter is not displayed.

**<Note>**

Read errors are displayed as “- - - - -.”

**In LTC+LUB and VTC+VUB display modes:**

Each combination is displayed separately.

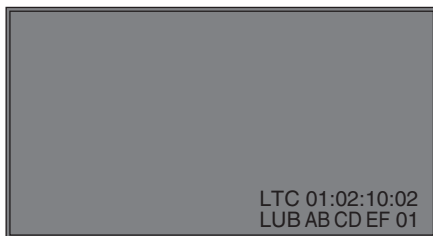
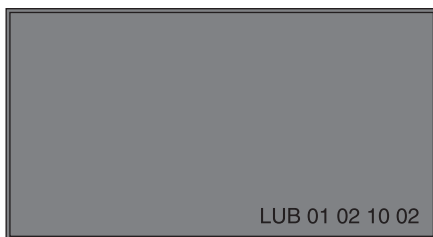

● QUAD screen



### Closed Caption (CC) Display

#### ● SINGLE screen

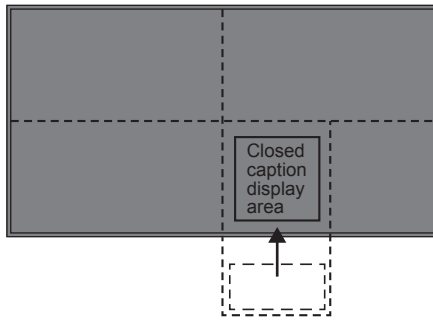

(When the specified window extends beyond the entire 1/8 screen)

- When an SDI signal is input, closed captions can be displayed.
- Closed captions comply with the following standards.  
HD-SDI CC Standard EIA/CEA-608 (708),  
EIA/CEA-708, OP-47
- The EIA/CEA-708 Standard allows the simultaneous display of closed captions at a specified location on up to eight windows.
- The display position is in a display area that is further inside than the 1/8 screen.  
(Refer to **<Note>** below.)
- The display settings can be set in the menu. Also, the display service (EIA/CEA-708) of the closed captions can be selected in the menu. (→page 47)

#### **<Note>**

- The position of the window specified by the closed caption information is in the display area.
- The window may extend beyond the display area depending on the position and size of the specified window. Such a window will be displayed but a window that extends beyond the 1/8 screen will be repositioned so that it is displayed inside the 1/8 screen.

# On-screen Menu Operations

## Main Menu (MAIN MENU)

- For details on how to open the main menu, refer to “Main Menu (MAIN MENU)/FUNCTION Menu/INPUT SELECT Menu Display” (→ page 16).

### 1. Turn the rotary knob <PICTURE> to select a menu item and press the rotary knob <PICTURE>.

- The submenu appears.

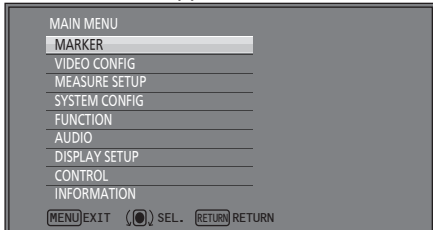

### 2. Turn the rotary knob <PICTURE> to select a submenu item and press the rotary knob <PICTURE>.

- The setting values in the submenu can be changed.

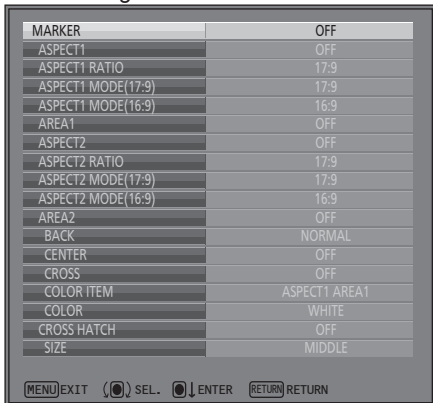

### 3. Turn the rotary knob <PICTURE> to select a setting value and press the rotary knob <PICTURE>.

- To cancel, press <RETURN/VOLUME> before pressing the rotary knob <PICTURE>.



### 4. To return to the previous screen, press <RETURN/VOLUME>.

## FUNCTION Menu

- For details on how to open the [FUNCTION] menu, refer to “Main Menu (MAIN MENU)/FUNCTION Menu/INPUT SELECT Menu Display” (→ page 16).

### 1. Turn the rotary knob <PICTURE> to select a function item.

- The setting status of the selected function item is indicated by green.

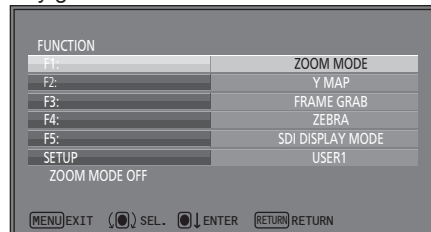

### 2. Press the rotary knob <PICTURE>.

- Each press of the rotary knob <PICTURE> changes the setting and performs the function.

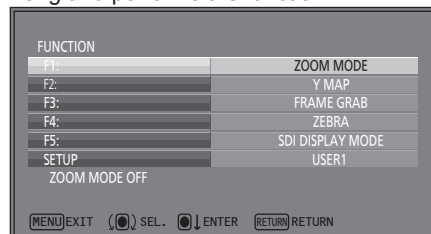

- The settings are the same as in the [FUNCTION] menu (→page 37) of MAIN MENU.

### 3. To return to the [TOP MENU] screen, press <RETURN/VOLUME>.

## INPUT SELECT Menu

- For details on how to open the [INPUT SELECT] menu, refer to “Main Menu (MAIN MENU)/FUNCTION Menu/INPUT SELECT Menu Display” (→ page 16).

### 1. Turn the rotary knob <PICTURE> to select an input signal connector or [INT-SG] and press the rotary knob <PICTURE>.

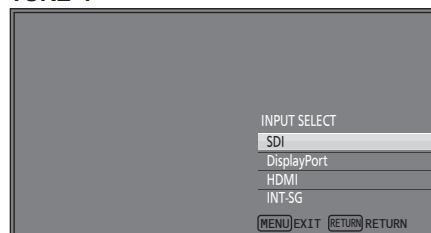

- SDI: Serial digital interface input
- DisplayPort: DisplayPort input
- HDMI: HDMI input
- INT-SG: Internal chart for adjustment (color bar + grayscale) (→page 71)

### 2. To return to the [TOP MENU] screen, press <RETURN/VOLUME>.

**Picture Adjustment (PICTURE) Menu**

1. Turn the rotary knob <PICTURE> to select a menu item and press the rotary knob <PICTURE>.

- The setting value of the selected menu item can be changed.

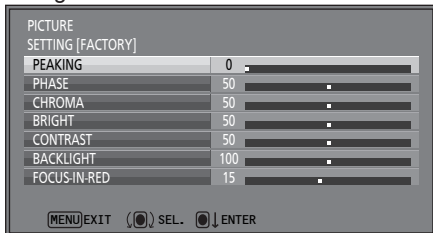

Name	Function	Adjustable range ( ): denotes the factory default.
PEAKING	PEAKING	0 to 60 (0)
PHASE	PHASE	0 to 100 (50)
CHROMA	CHROMA	0 to 100 (50)
BRIGHT	BRIGHT	0 to 100 (50)
CONTRAST	CONTRAST	0 to 100 (50)
BACKLIGHT	BACKLIGHT	0 to 200 (100)
FOCUS-IN-RED	FOCUS-IN-RED	1 to 30 (15)

The position pointer color is green only for values that are the factory default, and is white for the other values. The settings are loaded when the unit is turned on. However, operations and changes are not possible in the following cases.

- When the control lock is on, the mark is displayed and the settings cannot be changed. (→page 48)
- [PEAKING] displays the outline correction edge on the outer perimeter of the screen in SINGLE screen or QUAD screen mode.
- When [MONO] (→page 29) is set to [ON], the [PHASE] and [CHROMA] operations are disabled.
- [FOCUS-IN-RED] is enabled during operation of the FOCUS-IN-RED function.
- When [BLACK MODE] (→page 37) is set to [ON], the [CONTRAST] and [BACKLIGHT] operations are disabled.

2. Turn the rotary knob <PICTURE> to select a setting value and press the rotary knob <PICTURE>.

- The set value is confirmed and the menu reappears.
- To cancel, press <MENU> before pressing the rotary knob <PICTURE>.



- When the picture adjustment values ([PEAKING]/[PHASE]/[CHROMA]/[BRIGHT]/[CONTRAST]/[BACKLIGHT]) are changed from the factory defaults, the position pointers are displayed in white.

**Audio Volume**

- For details on how to display the audio volume, refer to “Audio Volume Display” (→ page 17).

1. Turn the rotary knob <PICTURE> to select a setting value.



- Setting values are confirmed when they are changed.
- Changing the audio volume when the audio output is muted (→ “AUDIO MUTE” page 37) immediately cancels the mute state.
- VOLUME(X) is displayed when audio output of the unit is muted.
- Audio volume is always available and is not affected by the [CONTROL] menu (→page 48).
- The adjustment range is 0 to 60 (the factory default is 0).

# User Data

This unit can save up to five combinations of set values for MAIN MENU and screen adjustments made in the [PICTURE] (picture adjustment) menu as user data that can be recalled.

You can also return set values and adjustments to their factory defaults.

User data includes the following settings.

- Menu settings except [SETUP LOAD]/[SETUP SAVE] and [REMOTE] in [CONTROL] (includes the function settings of the buttons on the front panel of the unit)
- Screen adjustments made with the rotary knob <PICTURE>

## Saving User Data

1. Press <MENU> to display the main menu.
2. Turn the rotary knob <PICTURE> to select the [SYSTEM CONFIG] menu and press the rotary knob <PICTURE>.
3. Turn the rotary knob <PICTURE> to select the [SETUP SAVE] submenu and press the rotary knob <PICTURE>. The setting values in the submenu can be changed.

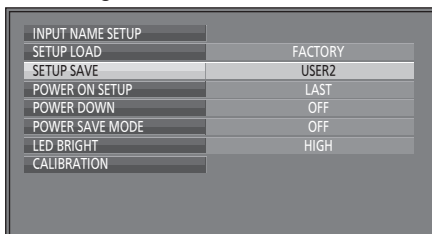

INPUT NAME SETUP	
SETUP LOAD	FACTORY
SETUP SAVE	USER2
POWER ON SETUP	LAST
POWER DOWN	OFF
POWER SAVE MODE	OFF
LED BRIGHT	HIGH
CALIBRATION	

4. Turn the rotary knob <PICTURE> to select the setup to save from [USER1] to [USER5] and press the rotary knob <PICTURE>.

The following screen appears.

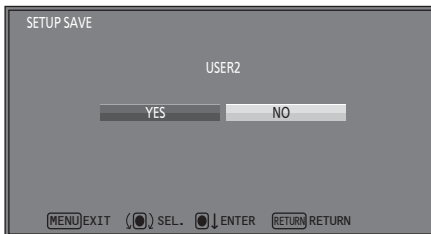

5. Select [YES] and press the rotary knob <PICTURE>.

The user data is saved.

6. To return to the previous screen, press <RETURN/VOLUME>.

## Loading User Data

1. Press <MENU> to display the main menu.
2. Turn the rotary knob <PICTURE> to select the [SYSTEM CONFIG] menu and press the rotary knob <PICTURE>.
3. Turn the rotary knob <PICTURE> to select the [SETUP LOAD] submenu and press the rotary knob <PICTURE>. The setting values in the submenu can be changed.

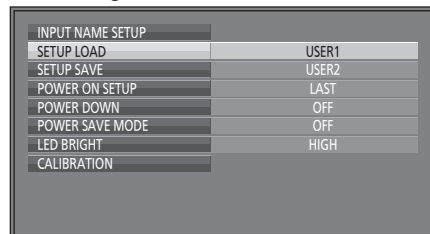

INPUT NAME SETUP	
SETUP LOAD	USER1
SETUP SAVE	USER2
POWER ON SETUP	LAST
POWER DOWN	OFF
POWER SAVE MODE	OFF
LED BRIGHT	HIGH
CALIBRATION	

4. Turn the rotary knob <PICTURE> to select the setup to load from [USER1] to [USER5] and press the rotary knob <PICTURE>.

The following screen appears.

- To return the settings to the factory defaults, select [FACTORY].

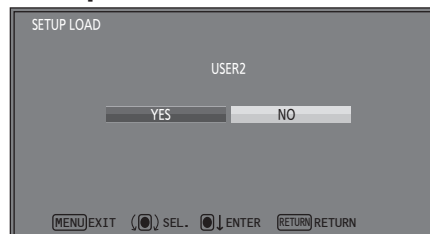

5. Select [YES] and press the rotary knob <PICTURE>.

The user data is loaded.

6. To return to the previous screen, press <RETURN/VOLUME>.

- The selection items of [FACTORY] are [YES(ALL)], [YES(EXCEPT USER)], and [NO].  
YES(ALL): Initializes the data including USER DATA\*1.  
YES(EXCEPT USER): Initializes the data except USER DATA.

\*1 USER DATA is the data you uploaded with the FILM GAMMA and COLOR SPACE(LUT) items.

# Main Menu

## Menu Configuration

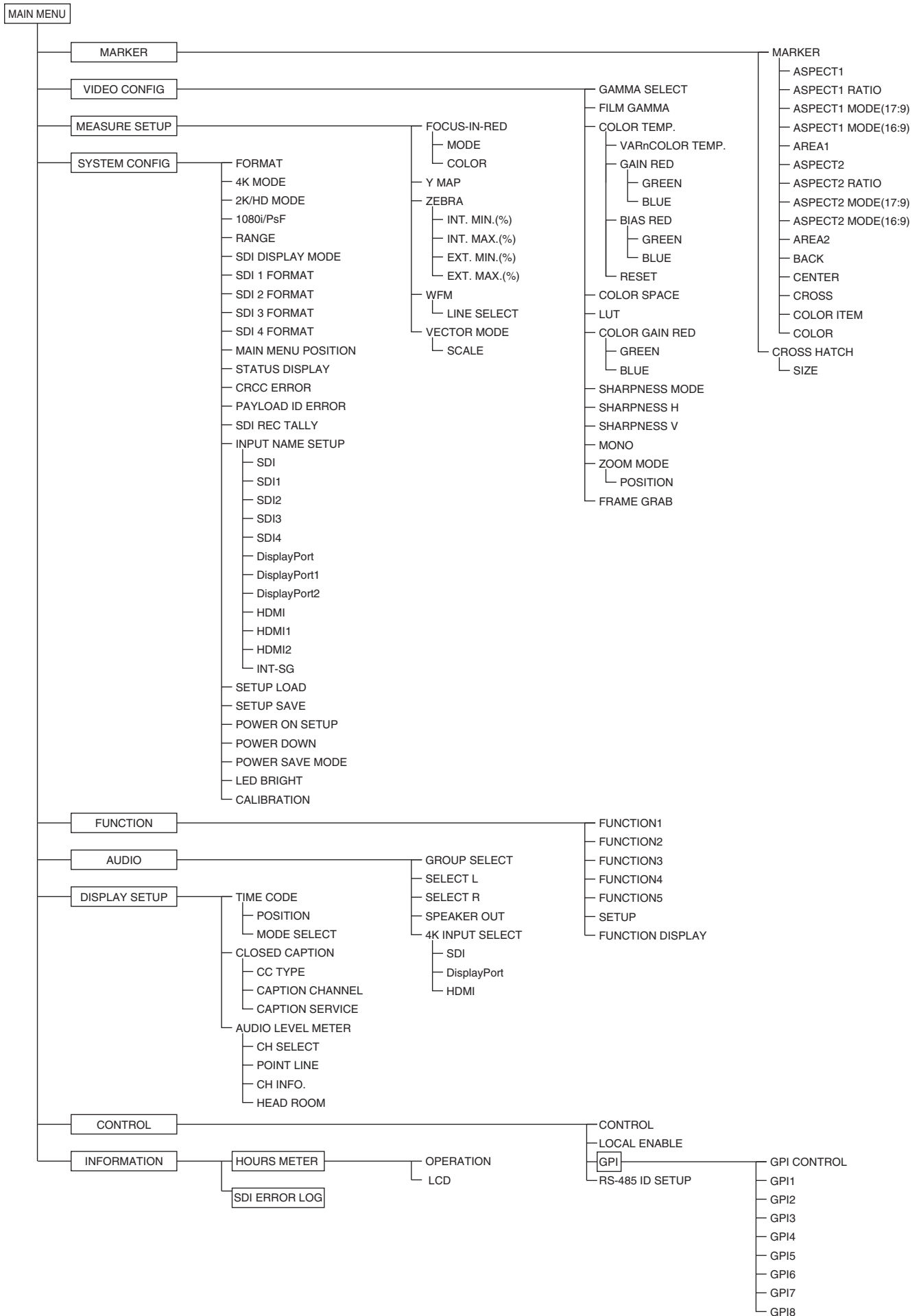

## MARKER

The underlined values are the factory defaults.

Submenu	Setting	Description
<b>MARKER</b>	<u>OFF</u> *1 ON	Selects whether to enable or disable the marker setting.
<b>ASPECT1</b>	<u>OFF</u> ON	Displays the aspect 1 marker. [OFF] Not displayed [ON] Displayed
<b>ASPECT1 RATIO</b>	<u>17:9</u> 16:9	Sets the ratio of marker 1. [17:9] 17:9 [16:9] 16:9
<b>ASPECT1 MODE (17:9) *2</b>	<u>17:9</u> 16:9 4:3 13:9 14:9 CNSCO 2.39 CNSCO 2.35 2:1 VISTA	Selects/displays the marker type for when ASPECT1 RATIO is 17:9. [17:9] 17:9 marker [16:9] 16:9 marker [4:3] 4:3 marker [13:9] 13:9 marker [14:9] 14:9 marker [CNSCO 2.39] 2.39:1 marker [CNSCO 2.35] 2.35:1 marker [2:1] 2:1 marker [VISTA] VISTA marker
<b>ASPECT1 MODE (16:9) *2</b>	<u>16:9</u> 4:3 13:9 14:9 CNSCO 2.39 CNSCO 2.35 2:1 VISTA	Selects/displays the marker type for when ASPECT1 RATIO is 16:9. • For each item, refer to ASPECT1 MODE(17:9).
<b>AREA1 *4</b>	<u>OFF</u> 95% 93% 90% 88% 80% USER 85% VAR. H. 85% V. 85% DOT hhhh xxxx LINE vvvv yyyy	Selects/displays the area marker type of the marker set in ASPECT1 RATIO. [OFF] No marker display [95%] 95 % area marker [93%] 93 % area marker [90%] 90 % area marker [88%] 88 % area marker [80%] 80 % area marker [USER] An area marker that is adjustable in 1 % increments within the range of 80 % to 100 %. (The factory default is 85 %.) *3 [VAR.] An area marker that is adjustable in 1 % increments within the range of 80 % to 100 % separately for vertical and horizontal. (The factory default is 85 % for both vertical and horizontal.) *3 [DOT]/[LINE] An area marker that can be moved in increments of 1 dot/1 line within the 0000 to 4094 range variable in the H direction (hhhh/xxxx) and the 0000 to 2158 range variable in the V direction (vvvv/yyyy). Select DOT or LINE, and then set each of the beginning and end. The value in the H direction is variable when DOT is selected, and the value in the V direction is variable when LINE is selected. (The factory defaults are DOT: 0000/4094 and LINE: 0000/2158.)
<b>ASPECT2</b>	<u>OFF</u> ON	Displays the aspect 2 marker. • For each item, refer to ASPECT1.
<b>ASPECT2 RATIO</b>	<u>17:9</u> 16:9	Sets the ratio of marker 2. • For each item, refer to ASPECT1 RATIO.

\*1 When a marker related control signal is received during REMOTE operation, this setting becomes [ON].

\*2 An aspect marker is not displayed if ASPECT1 MODE is 17:9 when 17:9 is selected for ASPECT RATIO. (Only the area marker will be displayed.)

\*3 Since video is displayed at 100 %, markers are not displayed if the marker setting is set to [100%].

\*4 Displayed when the marker type set in ASPECT1 RATIO/ASPECT2 RATIO is 17:9, 16:9, or 4:3.

(Continued on next page)



## Main Menu (Continued)

Submenu	Setting	Description
<b>ASPECT2 MODE (17:9) *2</b>	17:9 16:9 4:3 13:9 14:9 CNSCO 2.39 CNSCO 2.35 2:1 VISTA	Selects/displays the marker type for when ASPECT2 RATIO is 17:9. • For each item, refer to ASPECT1 MODE(17:9).
<b>ASPECT2 MODE (16:9) *2</b>	16:9 4:3 13:9 14:9 CNSCO 2.39 CNSCO 2.35 2:1 VISTA	Selects/displays the marker type for when ASPECT2 RATIO is 16:9. • For each item, refer to ASPECT1 MODE(17:9).
<b>AREA2 *4</b>	OFF 95% 93% 90% 88% 80% USER 85% VAR. H. 85% V. 85% DOT hhhh xxxx LINE vvvv yyyy	Selects/displays the area marker type of the marker set in ASPECT2 RATIO. • For each item, refer to AREA1.
<b>BACK *5</b>	<u>NORMAL</u> HALF BLACK	Selects the background brightness around the marker. [NORMAL] Normal background [HALF] 50 % signal level [BLACK] 0 % signal level (black)
<b>CENTER</b>	OFF ON	Displays the center marker. [OFF] Not displayed [ON] Displayed
<b>CROSS</b>	OFF (H. xxxx V. yyyy)	Displays the cross marker. [OFF] Not displayed [(H. xxxx V. yyyy)] Displayed Display is possible in any horizontal (H: 0020 to 4075) and vertical (V: 0020 to 2139) positions. When a set value [(H. xxxx V. yyyy)] has been confirmed, press the rotary knob <PICTURE> again to enter each of the horizontal and vertical positions. (The factory defaults are H: 0960 and V: 0540.)
<b>COLOR ITEM</b>	<u>ASPECT1 AREA1</u> ASPECT2 AREA2 CENTER CROSS	Selects the marker color selection type. [ASPECT1 AREA1] Aspect 1 and area 1 marker [ASPECT2 AREA2] Aspect 2 and area 2 marker [CENTER] Center marker [CROSS] Cross marker
<b>COLOR</b>	WHITE BLACK RED GREEN BLUE	Selects the marker color of the item displayed in COLOR ITEM. [WHITE] white [BLACK] black [RED] red [GREEN] green [BLUE] blue

\*2 An aspect marker is not displayed if ASPECT1 MODE is 17:9 when 17:9 is selected for ASPECT RATIO. (Only the area marker will be displayed.)

\*4 Displayed when the marker type set in ASPECT1 RATIO/ASPECT2 RATIO is 17:9, 16:9, or 4:3.

\*5 This is enabled only for a marker set in ASPECT1 MODE.

(Continued on next page)

## Main Menu (Continued)

---

Submenu	Setting	Description
<b>CROSS HATCH</b>	<u>OFF</u> LOW HIGH	Sets the display and density of the cross hatch. [OFF] Not displayed [LOW] Displays a dim cross hatch [HIGH] Displays a bright cross hatch
<b>SIZE</b>	SMALL MIDDLE <u>LARGE</u>	Selects the cross hatch size. [SMALL] 60 dots and 60 lines [MIDDLE] 120 dots and 120 lines [LARGE] 240 dots and 240 lines

**<Note>**

- In PIXEL TO PIXEL mode, markers other than CROSS HATCH are not available.

**MARKER Types**

■ **Marker for 17:9 and 16:9**

The marker is only displayed as a vertical bar. In addition, the  section becomes the "MARKER BACK" item.



4:3 marker

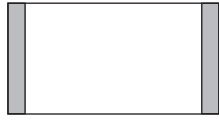

13:9 marker



14:9 marker



16:9 marker

**VISTA marker, 2:1 marker, and CNSCO marker**

A vertical marker may not be displayed depending on the aspect ratio setting.



VISTA marker



2:1 marker



CNSCO marker (2.35/2.39)

**Area marker**

This marker is displayed as a dotted line.

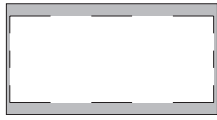

95 % area marker

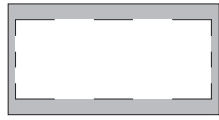

93 % area marker



90 % area marker



88 % area marker

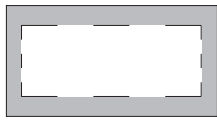

80 % area marker

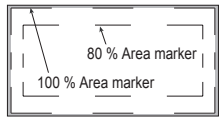

USER area marker\*1  
VAR area marker\*2  
DOT/LINE marker\*3

**<Display marker of 17:9 and 16:9>**

The marker is displayed based on each screen size.



17:9 size



16:9 size

■ **Marker for 4:3**

This marker is displayed as a dotted line.

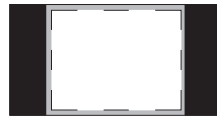

95 % area marker

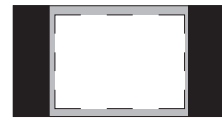

93 % area marker

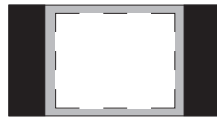

90 % area marker

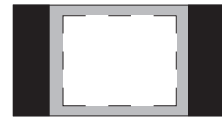

88 % area marker

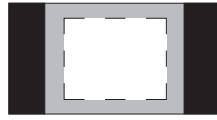

80 % area marker

This marker is displayed as a dotted line.

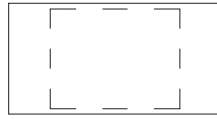

95 % area marker

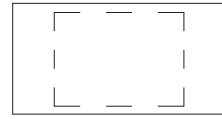

93 % area marker

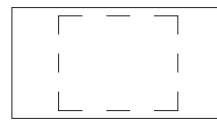

90 % area marker

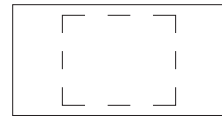

88 % area marker

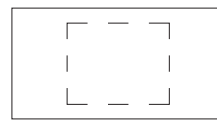

80 % area marker

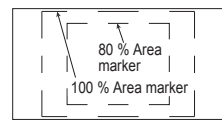

USER area marker\*1  
VAR area marker\*2  
DOT/LINE marker\*3

**The marker can be displayed simultaneously with the markers for 17:9 and 16:9.**

Simultaneous display example

The  section becomes the "MARKER BACK" item. It controls the background of the marker selected in ASPECT1.

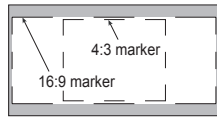

16:9 marker: 95 % area marker  
4:3 marker: 80 % area marker

■ **Center marker**

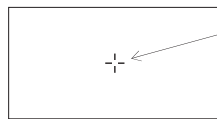

Center marker  
This marker is displayed at the center of the screen.

■ **Cross marker**



Cross marker  
Use the rotary knob <PICTURE> to move the marker. (The cross marker is half the length of the center marker and twice the width)

\*1 Use the rotary knob <PICTURE> to set 80 % to 100 % in 1 % increments.

\*2 Use the rotary knob <PICTURE> to set 80 % to 100 % in 1 % increments separately for vertical and horizontal.

\*3 Use the rotary knob <PICTURE> to set the H direction: 0000 to 4094 and V direction: 0000 to 2158 in increments of 1 separately for vertical and horizontal.

## VIDEO CONFIG

The underlined values are factory defaults.

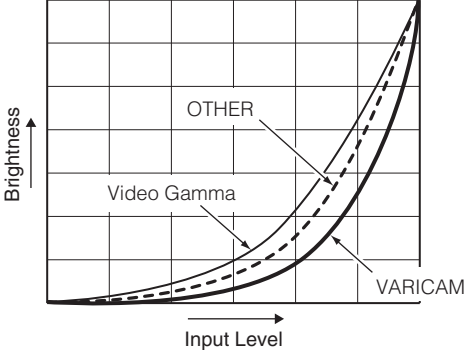
Submenu	Setting	Description
<b>GAMMA SELECT</b> *1	2.20 <u>2.35</u> 2.40 2.60 FILM 1.00 to 3.00 (MANUAL SET)	<p>Selects the gamma curve.</p> <p>[2.20] Identical to STANDARD of BT-LH Series            [2.35] Identical to STDIO/PST of BT-LH Series            [2.40] CRT approximation mode            [2.60] Identical to CINEMA of BT-LH Series            [FILM] Film mode            [1.00 to 3.00(MANUAL SET)] The gamma curve can be arbitrary changed in increments of 0.05.</p> <ul style="list-style-type: none"> <li>When [FILM] is selected, the <b>FILM</b> mark is displayed for the operating status.</li> <li>The gamma curve setting is reflected for the video not while the setting item is being changed but after the change has been confirmed.</li> </ul>
<b>FILM GAMMA</b>	<u>VARICAM</u> OTHER USER1 USER2 USER3	<p>Selects the FILM gamma mode type.</p> <p>[VARICAM] For VARICAM            [OTHER] Other            [USER1/USER2/USER3] Allows you to select a user-defined value. (Factory default setting: VARICAM)</p> <ul style="list-style-type: none"> <li>For details on user downloads, refer to the user customization function. (→page 72)</li> </ul> <p>(Gamma curve image)</p>  <p>The graph shows three gamma curves on a grid. The vertical axis is labeled 'Brightness' and the horizontal axis is 'Input Level'. A solid line represents 'Video Gamma', a dashed line represents 'OTHER', and a dotted line represents 'VARICAM'. The VARICAM curve is the steepest, followed by OTHER, and Video Gamma is the least steep.</p>
<b>COLOR TEMP.</b>	USER 0 to 63 *2 D93 <u>D65</u> D63 D60 D56 CINEMA VAR1 *3 VAR2 *3 VAR3 *3	<p>Selects the color temperature.</p> <p>[USER 0 to 63] Setting adjustable within the range of 0 to 63 (equivalent to a color temperature range of 3 000 K to 9 300 K)</p> <p>[D93] Equivalent to a color temperature of 9 300 K            [D65] Equivalent to a color temperature of 6 500 K            [D63] Equivalent to a color temperature of 6 300 K            [D60] Equivalent to a color temperature of 6 000 K            [D56] Equivalent to a color temperature of 5 600 K            [CINEMA] Equivalent to the x: 0.314 and y: 0.351 values in the CIE chromaticity coordinates.</p> <p>[VAR1] WB (WHITE BALANCE) adjustment mode            [VAR2] WB (WHITE BALANCE) adjustment mode            [VAR3] WB (WHITE BALANCE) adjustment mode</p>
<b>VARnCOLOR TEMP.</b>	USER 0 to 63 D93 <u>D65</u> D63 D60 D56 CINEMA	<p>Selecting [VAR1] to [VAR3] in [COLOR TEMP.] allows you to adjust WHITE BALANCE VAR1 to VAR3.</p>

\*1 This is grayed out when the same item is set for GPI and [GPI CONTROL] is set to [ENABLE].

\*2 To select [USER 0 to 63]

(1) Press the rotary knob &lt;PICTURE&gt;.

(2) Use the rotary knob &lt;PICTURE&gt; to select 0 to 63 and press the rotary knob &lt;PICTURE&gt;.

\*3 If [VAR1], [VAR2], or [VAR3] is selected, the mode becomes WB adjustment mode.

## Main Menu (Continued)

Submenu	Setting	Description
<b>GAIN RED</b>	0 to 1023 (The factory default setting values are the values of the [D65] color temperature.)	Adjusts the GAIN elements for RED.
<b>GREEN</b>		Adjusts the GAIN elements for GREEN.
<b>BLUE</b>	• The factory default adjustment values will be set.	Adjusts the GAIN elements for BLUE.
<b>BIAS RED</b>	-512 to 511	Adjusts the BIAS elements for RED.
<b>GREEN</b>	(Factory default setting: 0)	Adjusts the BIAS elements for GREEN.
<b>BLUE</b>		Adjusts the BIAS elements for BLUE.
<b>RESET</b>		Resets the setting values of [GAIN] (RED/GREEN/BLUE) and [BIAS] (RED/GREEN/BLUE) to the values of the color temperature selected in [COLOR TEMP].
<b>COLOR SPACE</b>	<u>SMPTE-C</u> EBU ITU-709 *4 DCI-P3 NATIVE	Sets the studio standard color shade. [NATIVE] Displays the color space of the three RGB primary colors unique to BT-4LH310P/BT-4LH310E. (This is the maximum color gamut that can be represented by BT-4LH310P/BT-4LH310E.) • Factory default setting BT-4LH310P: SMPTE-C BT-4LH310E: EBU
<b>LUT</b>	<u>STANDARD</u> USER1-3	Reproduces colors in accordance with the set COLOR SPACE using the 3D LUT (look up table). [STANDARD] Reproduces colors with the standard 3D LUT. [USER1/USER2/USER3] Allows you to select a user setting value. (Factory default setting: STANDARD) • For details on user downloads, refer to the user customization function (→page 72).
<b>COLOR GAIN RED</b>	0 to 60	Finely adjusts RED GAIN. 0 to 60 (Factory default setting: 30)
<b>GREEN</b>	0 to 60	Finely adjusts GREEN GAIN. 0 to 60 (Factory default setting: 30)
<b>BLUE</b>	0 to 60	Finely adjusts BLUE GAIN. 0 to 60 (Factory default setting: 30)
<b>SHARPNESS MODE *5</b>	<u>HIGH</u> LOW	Selects the width of the outline correction edge. [HIGH] Narrow edge [LOW] Wide edge
<b>SHARPNESS H *5</b>	0 to 60	Sets horizontal outline correction.
<b>SHARPNESS V *5</b>	0 to 60	Sets vertical outline correction.
<b>MONO *1</b>	<u>OFF</u> ON	Switches between color and monochrome (MONO). [OFF] Color [ON] Monochrome • When [ON], the [CHROMA] setting is fixed to 0 and the [PHASE] setting is fixed to 50 in the [PICTURE] (picture adjustment) menu.
<b>ZOOM MODE</b>	<u>OFF</u> ON	Sets the zoom function for 4K signals (4096 x 2160 or 3840 x 2160). [OFF] Normal display [ON] Zooms to 4x.
<b>POSITION</b>	<u>CENTER</u> LT RT RB LB	Sets the display position for the zoom function. [CENTER] Center [LT] Top left position [RT] Top right position [RB] Bottom right position [LB] Bottom left position
<b>FRAME GRAB</b>	<u>OFF</u> ON	Sets the function for freezing the screen display when one screen. [OFF] Normal display [ON] Still image display

\*1 This is grayed out when the same item is set for GPI and [GPI CONTROL] is set to [ENABLE].

\*4 ITU-709 is an ITU-R BT.709 standard.

\*5 This displays the outline correction edge on the outer perimeter of the screen in SINGLE screen or QUAD screen mode.

## Main Menu (Continued)

### MEASURE SETUP

The underlined values are the factory defaults.

Submenu	Setting	Description
<b>FOCUS-IN-RED*1</b>	<u>OFF</u> ON	Sets the FOCUS-IN-RED function operation. [OFF] FOCUS-IN-RED function OFF [ON] FOCUS-IN-RED function ON
<b>MODE</b>	<u>NORMAL</u> PRECISE	[NORMAL] Matched to the characteristics of the same function of the BT-LH series. [PRECISE] This mode emphasizes subtle differences to enable more precise focus adjustment.
<b>COLOR</b>	<u>RED</u> BLUE MONO	Selects the color of outlines of the FOCUS-IN-RED function. [RED] red [BLUE] blue [MONO] Mono (Function for displaying the part that is in focus in white, and the other parts in black.)
<b>Y MAP</b>	<u>OFF</u> ON	Sets the Y MAP function operation. [OFF] Normal display [ON] Y MAP display
<b>ZEBRA*1*2</b>	<u>OFF</u> INT. EXT. INT.+EXT.	Sets the ZEBRA function operation. [OFF] Normal display [INT.] ZEBRA display (INT.) [EXT.] ZEBRA display (EXT.) [INT.+EXT.] ZEBRA display (INT.+EXT.)
<b>INT. MIN. (%)</b>	-7 to 108 (Factory default setting: <u>70</u> )	Sets the range for the effect of the ZEBRA function. Displays the minimum value of the INT. range as a percentage of the video signal.
<b>INT. MAX. (%)</b>	-6 to 109 (Factory default setting: <u>85</u> )	Sets the range for the effect of the ZEBRA function. Displays the maximum value of the INT. range as a percentage of the video signal.
<b>EXT. MIN. (%)</b>	-7 to 108 (Factory default setting: <u>5</u> )	Sets the range for the effect of the ZEBRA function. Displays the minimum value of the EXT. range as a percentage of the video signal.
<b>EXT. MAX. (%)</b>	-6 to 109 (Factory default setting: <u>100</u> )	Sets the range for the effect of the ZEBRA function. Displays the maximum value of the EXT. range as a percentage of the video signal.
<b>WFM</b>	<u>WFM Y</u> WFM R WFM G WFM B	Selects the type of WFM for when MULTI FUNCTION. [WFM Y] to [WFM B] Displays waveforms.
<b>LINE SELECT</b>	<u>ALL</u> LINE xxxx	Selects the display mode of WFM. [ALL] Displays WFM. [LINE xxxx] Displays only the selected line. <Variable range> 1080i (Line <u>0021</u> to Line 0560) 1080p (Line <u>0042</u> to Line 1121) 720p (Line <u>0026</u> to Line 0745) <Note> • The factory defaults are the underlined values. • This can be set for each input signal format.
<b>VECTOR MODE</b>	<u>×1</u> ×2S ×2 ×4 ×8	Enlarges vector waveforms. [×1] x1 [×2S] At x1 scale display only waveforms are enlarged to 2x. [×2] x2 [×4] x4 [×8] x8
<b>SCALE</b>	75% <u>100%</u>	Sets the scale of a vector waveform. [75%] Displays at 75 % scale. [100%] Displays at 100 % scale.

\*1 This is grayed out when the same item is set for GPI and [GPI CONTROL] is set to [ENABLE].

\*2 The ZEBRA function must be set according to the following conditions.

- [INT. MIN.] < [INT. MAX.]
- [EXT. MIN.] < [EXT. MAX.]
- [EXT. MIN.] ≤ [INT. MIN.]
- [INT. MAX.] ≤ [EXT. MAX.]

## SYSTEM CONFIG

The underlined values are the factory defaults.

Submenu	Setting	Description
<b>FORMAT</b>	<u>AUTO</u> 4K 2K/HD/PC	Sets the signal format for the entire system. [ <u>AUTO</u> ] Determined automatically from the input signal. [4K] 4K signal [2K/HD/PC] 2K/HD/PC signal
<b>4K MODE</b>	<u>AUTO</u> 4096 3840	Selects the format for when 4K signal. [ <u>AUTO</u> ] Determined automatically from the input signal. [4096] 4096x2160 [3840] 3840x2160
<b>2K/HD MODE</b>	<u>AUTO</u> 2K HD	Selects the format for when 2K/HD signal. [ <u>AUTO</u> ] Determined automatically from the input signal. [2K] 2048x1080 [HD] 1920x1080 or 1280x720
<b>1080i/PsF</b>	<u>AUTO</u> i PsF	Selects the display mode for when a 1080i or 1080PsF signal is input. [ <u>AUTO</u> ] Determined automatically from the input signal. [i] Displays video signals for which IP conversion has been performed. [PsF] Displays video signals for which progressive conversion has been performed.
<b>RANGE</b>	<u>AUTO</u> FULL LIMITED	Sets the quantization range of input signals. [ <u>AUTO</u> ] Determined automatically from the input signal. [FULL] 0 (black level) to 1023 [10-bit]/4095 [12-bit] (white level) [LIMITED] 64 [10-bit]/256 [12-bit] (black level) to 940 [10-bit]/3760 [12-bit] (white level)
<b>SDI DISPLAY MODE</b>	<u>SINGLE</u> QUAD	Selects the display mode of SDI input. [ <u>SINGLE</u> ] Displays the selected input signal over the entire screen. [QUAD] Splits the screen into four and simultaneously displays the input signals of SDI1/2/3/4.
<b>SDI1 FORMAT</b>	<u>AUTO</u> 3G 4:2:2 YCbCr 10bit 3G 4:4:4 YCbCr 10bit 3G 4:4:4 RGB 10bit 3G 4:2:2 YCbCr 12bit 3G 4:4:4 YCbCr 12bit 3G 4:4:4 RGB 12bit 3G 4:4:4 XYZ 12bit	Selects the SDI1 input format. [ <u>AUTO</u> ] Determined automatically from the input signal. [3G 4:2:2 YCbCr 10bit] 3G 4:2:2 YCbCr 10-bit [3G 4:4:4 YCbCr 10bit] 3G 4:4:4 YCbCr 10-bit [3G 4:4:4 RGB 10bit] 3G 4:4:4 RGB 10-bit [3G 4:2:2 YCbCr 12bit] 3G 4:2:2 YCbCr 12-bit [3G 4:4:4 YCbCr 12bit] 3G 4:4:4 YCbCr 12-bit [3G 4:4:4 RGB 12bit] 3G 4:4:4 RGB 12-bit [3G 4:4:4 XYZ 12bit] 3G 4:4:4 XYZ 12-bit
<b>SDI2 FORMAT</b>	<u>AUTO</u> 3G 4:2:2 YCbCr 10bit 3G 4:4:4 YCbCr 10bit 3G 4:4:4 RGB 10bit 3G 4:2:2 YCbCr 12bit 3G 4:4:4 YCbCr 12bit 3G 4:4:4 RGB 12bit 3G 4:4:4 XYZ 12bit	Selects the SDI2 input format. • For each item, refer to [SDI1 FORMAT].
<b>SDI3 FORMAT</b>	<u>AUTO</u> 3G 4:2:2 YCbCr 10bit 3G 4:4:4 YCbCr 10bit 3G 4:4:4 RGB 10bit 3G 4:2:2 YCbCr 12bit 3G 4:4:4 YCbCr 12bit 3G 4:4:4 RGB 12bit 3G 4:4:4 XYZ 12bit	Selects the SDI3 input format. • For each item, refer to [SDI1 FORMAT].

## Main Menu (Continued)

Submenu	Setting	Description
<b>SDI4 FORMAT</b>	AUTO 3G 4:2:2 YCbCr 10bit 3G 4:4:4 YCbCr 10bit 3G 4:4:4 RGB 10bit 3G 4:2:2 YCbCr 12bit 3G 4:4:4 YCbCr 12bit 3G 4:4:4 RGB 12bit 3G 4:4:4 XYZ 12bit	Selects the SDI4 input format. • For each item, refer to [SDI1 FORMAT].
<b>MAIN MENU POSITION</b>	LT RT RB LB	Sets the display position of the main menu. [LT] Top left of the screen [RT] Top right of the screen [RB] Bottom right of the screen [LB] Bottom left of the screen
<b>STATUS DISPLAY</b>	OFF 3SEC OFF CONTINUE	Determines how (→page 16) operating status is displayed. [OFF] Not displayed. [3SEC OFF] Displayed for approximately 3 seconds after a status change. *1 [CONTINUE] Always displayed
<b>CRCC ERROR</b>	OFF ON	Displays a CRCC error for SDI. [OFF] Not displayed [ON] Displayed
<b>PAYLOAD ID ERROR</b>	OFF ON	Displays a payload ID error for SDI. [OFF] Not displayed [ON] Displayed
<b>SDI REC TALLY</b>	OFF TYPE1 TYPE2 TYPE3	Lights the red tally when SDI REC information is superimposed. [OFF] Not displayed [TYPE1] Lights the red tally in accordance with the record/stop signal in the LTC information added to the HD SDI. [TYPE2] Lights the red tally in accordance with the record/stop signal in the SVITC information added to the HD SDI. [TYPE3] Checks the information when another company's camera recorder is used and lights the red tally accordingly.  <Note> • For details on TYPE1 or TYPE2, refer to "Panasonic Camera Recorders and Record/Stop Signals (Recording Mark)" (→page 33). • When [GPI CONTROL] is [ENABLE] and the tally item is assigned, tally control from the GPI takes priority.
<b>INPUT NAME SETUP</b>		Changes the names of the input connectors to be displayed on the status display screen and other screens. *2
<b>SETUP LOAD</b>	FACTORY USER1 *3 USER2 *3 USER3 *3 USER4 *3 USER5 *3	Loads the saved factory defaults ([FACTORY]) or user data ([USER1] to [USER5]). (→page 22) After user data is loaded, the screen displays the signal selected before the user data was loaded.
<b>SETUP SAVE</b>	USER1 USER2 USER3 USER4 USER5	Saves up to 5 sets of user data. (→page 22) Menu settings, except [SETUP SAVE]/[SETUP LOAD], and adjustment values made with the rotary knob <PICTURE> can be saved.
<b>POWER ON SETUP</b>	LAST FACTORY USER1 USER2 USER3 USER4 USER5	Selects the settings to use when the power is turned on. [LAST] Starts up using the settings used immediately before the power was turned off. [FACTORY] Starts up using the factory defaults. [USER1] to [USER5] Starts up using USER registered settings.

\*1 When PIXEL TO PIXEL, [3SEC OFF] is equivalent to [CONTINUE].

\*2 Up to 12 characters can be entered for this monitor. Only alphabetic characters (English), numeric characters and symbols can be used.

\*3 [USER1] to [USER 5] and [FACTORY] have the same factory defaults.



## Main Menu (Continued)

Submenu	Setting	Description
<b>POWER DOWN</b>	OFF ON	Sets whether to turn off the power (power down) when no signal is input and no operation was performed for approximately 1 hour. [OFF] Not powered down. [ON] Powered down.
<b>POWER SAVE MODE</b>	OFF ON	Sets the power save mode [OFF] Power save mode is not enabled. [ON] Dims the backlight when the state of no signal being input ([NO SIGNAL]) continues for approximately 60 seconds. Signal input or menu operation restores the backlight to its normal brightness.
<b>LED BRIGHT</b>	HIGH LOW	Sets the brightness of the lamps (green) on the front of the unit. [HIGH] High brightness mode [LOW] Low brightness mode
<b>CALIBRATION</b>		Connect a CA-310 Display Color Analyzer and then execute calibration. The calibration data will also be restored to the factory defaults. (→ page 35, 36)

### ■ Panasonic Camera Recorders and Stop Signals (Recording Mark)

Model	Recording Mark TYPE	Remarks
<b>AJ-HDC27F, H</b>	TYPE1	
<b>AJ-HDX900</b>	TYPE1 / TYPE2	Before use with TYPE1, change the UB_MODE setting on the camera to FRAM_RATE, and before use with TYPE2, change the VITC_UB_MODE setting on the camera to FRAM_RATE.
<b>AJ-HDX400, A</b>		
<b>AJ-HDX400E</b>		
<b>AG-HPX555</b>		
<b>AG-HPX175</b>		
<b>AG-HPX305</b>		
<b>AG-HPX375</b>		
<b>AJ-HPX2100</b>		
<b>AJ-HPX3000</b>		
<b>AJ-HPX2700</b>		
<b>AJ-HPX3100</b>		
<b>AJ-HPX3700</b>		

#### <Note>

For details, refer to operating instructions for the corresponding camera recorders.

## INPUT NAME SETUP

The INPUT NAME SETUP function allows you to change the names of the input lines ([SDI], [SDI1], [SDI2], [SDI3], [SDI4], [DisplayPort], [DisplayPort1], [DisplayPort2], [HDMI], [HDMI1], [HDMI2], and [INT-SG]) that are displayed on the status display screen and other screens.

- From the [SYSTEM CONFIG] menu, turn the rotary knob <PICTURE> to select the [INPUT NAME SETUP] submenu and press the rotary knob <PICTURE>.

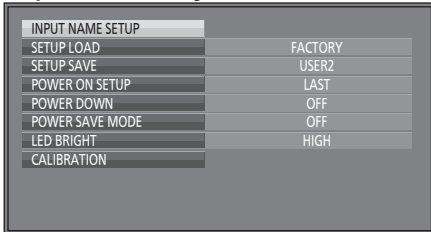

- Turn the rotary knob <PICTURE> to select the input line name you want to change and press the rotary knob <PICTURE>.

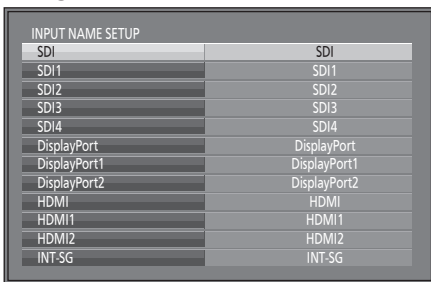

- Turn the rotary knob <PICTURE> to select the position of the character you want to change and press the rotary knob <PICTURE> to confirm the position.

- Turn the rotary knob <PICTURE> to move the cursor to the position to enter a character and press the rotary knob <PICTURE> to confirm the position.



- Turn the rotary knob <PICTURE> to select the character you want to enter and press the rotary knob <PICTURE> to confirm the selection.

- After entering all display characters, turn the rotary knob <PICTURE> to select [OK] and press the rotary knob <PICTURE> to confirm the display characters.



- To cancel the setting, press the rotary knob <PICTURE>, select [CANCEL] before confirming the display characters, and then press the rotary knob <PICTURE>.

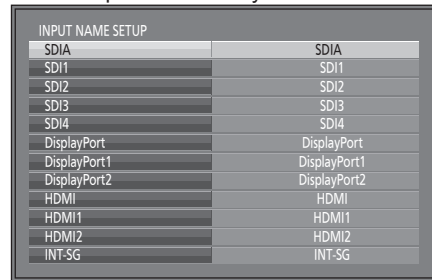

■ CALIBRATION

The CALIBRATION function of the unit measures LCD panel characteristics from low to high brightness values and uses internal monitor processing to perform calibration.

Calibration is performed using internal signals and does not rely on the image quality settings. The CALIBRATION function of the unit performs calibration with the color temperature of D65 and derives the other color temperatures from the result of that calculation.

■ Equipment required for calibration

- Konica Minolta CA-310 Display Color Analyzer (optional accessory)
- Konica Minolta CA-PU12 or CA-PU15 Standard Measurement Probe (optional accessory)
- RS-232C cable (male to male, straight) (optional accessory)  
Connect the RS-232C connector on the unit to the RS-232C connector on the display color analyzer.
- Set the baud rate setting of the display color analyzer to 38 400 bps.

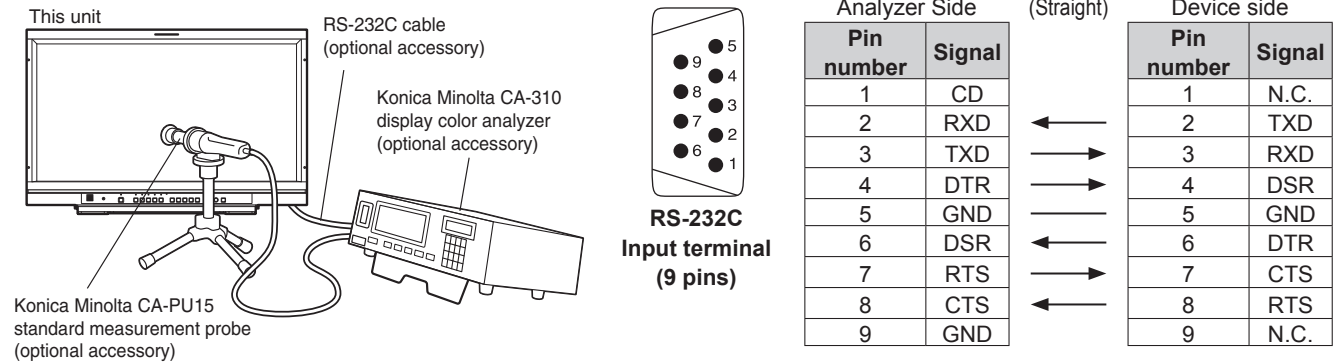

- Turn on the power of the unit and perform adequate aging (approximately 1 hour) before starting calibration.
- Make the room dark so that no external light can enter the standard measurement probe before starting the calibration. If external light enters the probe, the low brightness characteristics may not be calibrated correctly.
- LCD panel characteristics, instrument errors in the display color analyzer, and other factors may sometimes result in small differences in values after calibration.  
To further fine tune the monitor, set GAIN and BIAS for R, G, and B in the VAR mode of [COLOR TEMP.].
- If you are using CA-210, contact your supplier.

■ CALIBRATION

Select [CALIBRATION] in the [SYSTEM CONFIG] menu to open the following menus.

Submenu	Setting	Description
<b>AUTO CALIBRATION</b> *4		Connect a CA-310 Display Color Analyzer and then execute calibration. Select [AUTO CALIBRATION] and then select [YES] in the confirmation screen that appears to start calibration.
<b>RESET</b> *5		Returns the calibration data to the factory defaults. Select [RESET] and then select [YES] in the confirmation screen that appears to return the calibrated values to the factory defaults.

\*4 When AUTO CALIBRATION completes, [COMPLETE] appears. If it could not complete, [INCOMPLETE] appears.

\*5 When RESET completes, [COMPLETE] appears.

### Executing AUTO CALIBRATION

1. From the [SYSTEM CONFIG] menu, turn the rotary knob <PICTURE> to select the [CALIBRATION] submenu and press the rotary knob <PICTURE>.

2. Turn the rotary knob <PICTURE> to select the [AUTO CALIBRATION] submenu and press the rotary knob <PICTURE>.

3. Turn the power off and then back on after this operation.

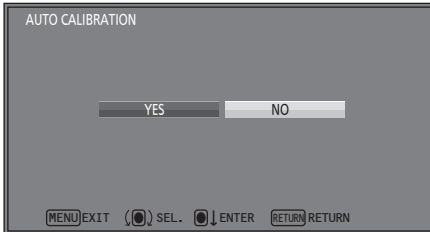

### Executing RESET

1. From the [SYSTEM CONFIG] menu, turn the rotary knob <PICTURE> to select the [CALIBRATION] submenu and press the rotary knob <PICTURE>.

2. Turn the rotary knob <PICTURE> to select the [RESET] submenu and press the rotary knob <PICTURE>.

3. Turn the power off and then back on after this operation.

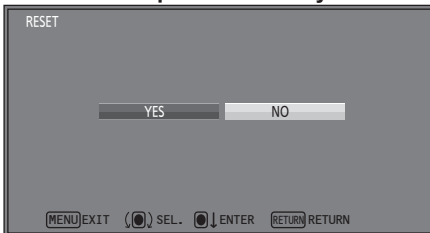

## FUNCTION

The underlined values are the factory defaults.

Submenu	Setting	Description
FUNCTION1 to FUNCTION5	BLUE ONLY	Selects the functions to assign to <FUNCTION1> to <FUNCTION5> (front panel buttons or [FUNCTION] menu).
	GAMMA SELECT	[BLUE ONLY] *1
	WHITE BALANCE	Cuts the red and green signals. Use this function to check the phase (PHASE) and chroma (CHROMA). Each press of the button toggles between ON and OFF.
	MONO	[GAMMA SELECT] *2*3
	BLACK MODE	Selects the gamma curve.
	R COLOR	[WHITE BALANCE]
	G COLOR	The adjustment screen for [GAIN]/[BIAS] of WHITE BALANCE can only be accessed when [VAR1] to [VAR3] is selected in [COLOR TEMP.].
	B COLOR	[MONO] *2*3
	SDI DISPLAY MODE	Switches between color and monochrome.
	ZOOM MODE	[BLACK MODE] *1*5
	ZOOM POSITION	This mode is for correcting black level errors and checking the gradation of dark areas.
	PIXEL TO PIXEL	The brightness of the backlight is reduced and the contrast is increased so that up to 75 % of the input signal level has the same gamma curve as the [GAMMA SELECT] setting. The signal level of 75 % or higher is clipped.
	FRAME GRAB	[R COLOR]*1
	DISPLAY SELECT	Cuts the red signals.
	MULTI FUNCTION	Each press of the button toggles between ON and OFF.
	PICTURE ASSIST	[G COLOR]*1
	WFM LINE SELECT	Cuts the green signals.
	AUDIO MUTE	Each press of the button toggles between ON and OFF.
	LEVEL METER	[B COLOR]*1
	TIME CODE	Cuts the blue signals.
	CLOSED CAPTION	Each press of the button toggles between ON and OFF.
	MARKER	[SDI DISPLAY MODE]
	FRAME MARKER	Toggles the SDI screen mode between [SINGLE] and [QUAD].
	OUTER LINE MARKER	[ZOOM MODE]
	CROSS HATCH	Switches the screen zoom mode for a 4K signal.
	FOCUS-IN-RED	[ZOOM POSITION]
	Y MAP	Switches the display position for screen zoom mode.
	ZEBRA	Turns the ZOOM function on or off.
	ZEBRA LEVEL	[PIXEL TO PIXEL]
	SCREEN SAVER	Turns the PIXEL TO PIXEL function on or off.
	LUT	[FRAME GRAB]
	UNDEF	Turns the FRAME GRAB function on or off.
	(Factory defaults	[DISPLAY SELECT]
FUNCTION1:	Selects the target selection screen for QUAD mode.	
ZOOM MODE	[MULTI FUNCTION]	
FUNCTION2:	Turns the MULTI FUNCTION function on or off.	
Y MAP	[PICTURE ASSIST]*1	
FUNCTION3:	Turns the PICTURE ASSIST function on or off.	
FRAME GRAB	[WFM LINE SELECT]	
FUNCTION4:	Switches the display mode of WFM.	
ZEBRA	[AUDIO MUTE]	
FUNCTION5:	Turns the audio volume MUTE function on or off.	
SDI DISPLAY MODE)	[LEVEL METER] *2	
	Turns the audio level meter display on or off.	

\*1 The settings are canceled when the power is turned OFF.

\*2 If these settings are changed, the menu settings will also change.

\*3 The control settings are not available during GPI operation.

\*5 High gradation portions are clipped. The backlight and contrast cannot be adjusted.

## Main Menu (Continued)

Submenu	Setting	Description
(Continued from the previous page)		<p>[TIME CODE] *2 Turns the time code display on or off.</p> <p>[CLOSED CAPTION] *2 Turns the closed caption display on or off. For details on the available operation items, refer to page 40.</p> <p>[MARKER] *2*4 Displays the marker. For details on the available operation items, refer to page 40.</p> <p>[FRAME MARKER] Displays the frame marker. Displays the marker on the outer perimeter of the panel.</p> <p>[OUTER LINE MARKER] Leaves the outer perimeter of the video and displays a halftone marker on the inside of it.</p> <p>[CROSS HATCH] *2 Displays the cross hatch.</p> <p>[FOCUS-IN-RED] *3*6 Turns the function that emphasizes the portion of the image in focus in red on or off.</p> <p>[Y MAP] *2 Turns the Y MAP function on or off.</p> <p>[ZEBRA] *2*3 Selects the ZEBRA function.</p> <p>[ZEBRA LEVEL] Displays the screen for adjusting the level of the ZEBRA function.</p> <p>[SCREEN SAVER] Turns the screen saver function on. Turns the panel backlight off to facilitate low power consumption and as a burn-in reduction measure in the event of burn-in on the panel. The function operation can be cancelled by front button operation or GPI operation.</p> <p>[LUT] Reproduces colors in accordance with the set COLOR SPACE.</p> <p>[UNDEF] Unset</p>
<b>SETUP</b> *7	USER1 USER2 USER3 USER4 USER5	Saves up to 5 sets of FUNCTION settings (FUNCTION 1 to 5).
<b>FUNCTION DISPLAY</b> *8	OFF ON1 ON2 *9	Sets the display of the functions assigned to <FUNCTION1> - <FUNCTION5> (front panel buttons). It also selects the button action (1- touch, 2-touch, off). [OFF] 1-touch action to perform function operations. Functions are not displayed. [ON1] 1-touch action to display functions and perform function operations. [ON2] 2-touch action to display functions and perform function operations.

- Pressing the <FUNCTION1> to <FUNCTION5> buttons will not perform the FUNCTION operations when the [PICTURE] (picture adjustment) menu has been displayed with the rotary knob <PICTURE>.

\*2 If these settings are changed, the menu settings will also change.

\*3 The control settings are not available during GPI operation.

\*4 This is not displayed when all of the [ASPECT1], [AREA1], [ASPECT2], [AREA2], [CENTER] and [CROSS] settings are [OFF] in the [MARKER] menu settings.

\*6 During the FOCUS-IN-RED operation, use the rotary knob <PICTURE> to change the detection sensitivity.

The setting range is from 1 to 30, with a higher numerical value resulting in a higher detection sensitivity (the focus becomes less sharp).

\*7 [USER1] to [USER 5] have the same factory defaults.

\*8 The operating status is displayed regardless of the ON/OFF setting.

\*9 When this is set to [ON2], the functions can be operated with the buttons when the functions are displayed.

(Continued on next page)

## Main Menu (Continued)

### ■ FUNCTION setting restrictions

Under the following conditions, "INVALID FUNCTION" is displayed and the settings cannot be set.

Setting	Condition or mode when operation not possible
BLUE ONLY	• When Y MAP ON
GAMMA SELECT	• When GPI item is set
WHITE BALANCE	• When other than VAR1 to VAR3 is selected in COLOR TEMP.
MONO	• When GPI item is set • When Y MAP ON
BLACK MODE	• When NO SIGNAL • When Y MAP ON • When PICTURE ASSIST ON
R COLOR	• When [BLUE ONLY ON] is selected • When Y MAP ON
G COLOR	• When [BLUE ONLY ON] is selected • When Y MAP ON
B COLOR	• When [BLUE ONLY ON] is selected • When Y MAP ON
SDI DISPLAY MODE	• When other than SDI input
ZOOM MODE	• When other than 4K signal input
ZOOM POSITION	• When other than 4K signal input
PIXEL TO PIXEL	• When GPI item is set • When other than 1280 × 720p signal input • When [INT-SG] is selected
FRAME GRAB	• When [INT-SG] is selected • When [SDI] is selected and SDI DISPLAY MODE is QUAD • When NO SIGNAL input
DISPLAY SELECT	• When SDI DISPLAY MODE is SINGLE • When SDI DISPLAY MODE is QUAD and MULTI FUNCTION is ON
MULTI FUNCTION	• When other than [SDI] is selected
PICTURE ASSIST	• When other than [SDI] is selected
WFM LINE SELECT	• When SDI DISPLAY MODE is SINGLE • When MULTI FUNCTION is other than ON • When WFM LINE SELECT is ALL
LEVEL METER	• When [INT-SG] is selected • When PICTURE ASSIST ON
TIME CODE	• When other than [SDI] is selected
CLOSED CAPTION	• When DisplayPort/HDMI is selected • When SDI DISPLAY MODE is QUAD • When 4K/PC signal input • When [INT-SG] is selected
MARKER	• When PICTURE ASSIST ON • When MULTI FUNCTION is ON • When [SDI] is selected and SDI DISPLAY MODE is QUAD • PIXEL TO PIXEL • When PC signal input
FRAME MARKER	• Refer to "MARKER" above.
OUTER LINE MARKER	• Refer to "MARKER" above.
FOCUS-IN-RED	• When GPI item is set • When BLUE ONLY ON is selected • When NO SIGNAL input • When INT-SG is selected • When Y MAP ON • When MULTI FUNCTION is ON
Y MAP	• When [INT-SG] is selected • When MULTI FUNCTION is ON
ZEBRA	• When Y MAP ON • When GPI item is set • When [INT-SG] is selected

### ■ Operation items displayed on the screen during FUNCTION button operation

Pressing any of the <FUNCTION1> to <FUNCTION5> buttons displays the operation assigned to the corresponding button as shown below.

Setting	Display
BLUE ONLY	[BLUE ONLY OFF] → [BLUE ONLY ON]
GAMMA SELECT	[GAMMA2.20] → [GAMMA2.35] → [GAMMA2.40] → [GAMMA2.60] → [GAMMA FILM] → [GAMMA*.** (MANUAL SET)]
WHITE BALANCE	[WHITE BALANCE VAR1/2/3]
MONO	[MONO OFF] → [MONO ON]
BLACK MODE	[BLACK MODE OFF] → [BLACK MODE ON]
R COLOR	[R COLOR ON] → [R COLOR OFF]
G COLOR	[G COLOR ON] → [G COLOR OFF]
B COLOR	[B COLOR ON] → [B COLOR OFF]

## Main Menu (Continued)

Setting	Display
<b>SDI DISPLAY MODE</b>	[SDI DISPLAY MODE SINGLE] → [SDI DISPLAY MODE QUAD]
<b>ZOOM MODE</b>	[ZOOM MODE OFF] → [ZOOM MODE ON]
<b>ZOOM POSITION</b>	[ZOOM POSITION CENTER] → [ZOOM POSITION LT] → [ZOOM POSITION RT] → [ZOOM POSITION RB] → [ZOOM POSITION LB]
<b>PIXEL TO PIXEL</b>	[PIXEL TO PIXEL OFF] → [PIXEL TO PIXEL ON]
<b>FRAME GRAB</b>	[FRAME GRAB OFF] → [FRAME GRAB ON]
<b>DISPLAY SELECT</b>	The displayed items differ depending on the mode. <ul style="list-style-type: none"> <li>When normal mode of QUAD mode [DISPLAY SELECT SDI1] → [DISPLAY SELECT SDI2] → [DISPLAY SELECT SDI3] → [DISPLAY SELECT SDI4]</li> <li>When PICTURE ASSIST mode of QUAD mode [AREA2] → [AREA3] → [AREA4]</li> </ul>
<b>MULTI FUNCTION</b>	[MULTI FUNCTION OFF] → [MULTI FUNCTION ON]
<b>PICTURE ASSIST</b>	[PICTURE ASSIST OFF] → [PICTURE ASSIST ON]
<b>WFM LINE SELECT</b>	[SETTING]
<b>AUDIO MUTE</b>	[AUDIO MUTE OFF] → [AUDIO MUTE ON]
<b>LEVEL METER</b>	[METER OFF] → [METER 2CH/4CH/8CH]
<b>TIME CODE</b>	[TC OFF] → [LTC/VTC/LUB/VUB/LTC+LUB/VTC+VUB]
<b>CLOSED CAPTION</b>	The displayed items differ depending on the [CC TYPE] selection. <ul style="list-style-type: none"> <li>When the [CC TYPE] setting is [CEA-608(708)]: [CC OFF] → [CC1/2/3/4]</li> <li>When the [CC TYPE] setting is [CEA-708]: [CC OFF] → [SRV1/2/3/4/5/6]</li> <li>When the [CC TYPE] setting is [OP-47]: [CC OFF] → [OP-47]</li> </ul>
<b>MARKER</b>	[MARKER OFF] → [RATIO Aspect Marker Type and Area Marker Type]*1 Splits each of the RATIO/Aspect Marker Type/Area Marker Type into the two lines Aspect Marker 1 and Aspect Marker 2, and displays the current setting values. <ul style="list-style-type: none"> <li>RATIO 17:9/16:9</li> <li>Aspect Marker Type 17:9/16:9/4:3/13:9/14:9/CNSCO 2.39/CNESCO 2.35/2:1/VISTA</li> <li>Area Marker Type 95%/93%/90%/88%/80%/xx%*2/yy%/zz%*3/DOThhh/xxxx/LINEvvv/yyyy*4</li> </ul> <p>*1 If an area marker is displayed when aspect marker is off, the aspect marker type is displayed.            *2 xx% indicates an 80% to 100% USER setting.            *3 yy%/zz% indicates the VAR setting when an 80% to 100% aspect ratio is specified.            *4 hhhh/xxxx indicates the H direction setting when the area marker DOTLINE is specified, and vvv/yyyy indicates the V direction setting.</p>
<b>FRAME MARKER</b>	[FRAME MARKER OFF] → [FRAME MARKER ON]
<b>OUTER LINE MARKER</b>	[OUTER LINE MARKER OFF] → [OUTER LINE MARKER ON]
<b>CROSS HATCH</b>	[CROSS HATCH OFF] → [CROSS HATCH LOW] → [CROSS HATCH HIGH]
<b>FOCUS-IN-RED</b>	[FOCUS-IN-RED OFF] → [FOCUS-IN-RED RED/BLUE/MONO]
<b>Y MAP</b>	[Y MAP OFF] → [Y MAP ON]
<b>ZEBRA</b>	[ZEBRA OFF] → [ZEBRA INT.] → [ZEBRA EXT.] → [ZEBRA INT.+EXT.]
<b>ZEBRA LEVEL</b>	[SETTING]
<b>SCREEN SAVER</b>	[SCREEN SAVER OFF] → [SCREEN SAVER ON]
<b>LUT</b>	[STANDARD] → [USER1] → [USER2] → [USER3]

### <Note>

- [WHITE BALANCE] and [ZEBRA LEVEL] are switched to the adjustment mode with a <FUNCTION> button but the operating status is not displayed.
- [\*\*\*/\*\*\*\*] indications (for example, [CC1/2/3/4]) vary depending on the menu setting.



■ **FUNCTION skip function**

This function allows you to skip some of the setting items of functions assigned to FUNCTION during FUNCTION operation. When the operations of the functions assigned to <FUNCTION1> to <FUNCTION5> in the FUNCTION menu are performed, a submenu that allows you to skip the setting items of the functions appears. Set the setting items you want to skip during FUNCTION operation to [OFF].

A submenu appears for the following functions.

[GAMMA SELECT]/[ZOOM POSITION]/[DISPLAY SELECT]/[CROSS HATCH]/[ZEBRA]

<<Setting example>>

Select [ZEBRA] in the [FUNCTION] menu and press the rotary knob <PICTURE> to open the submenu shown below.

**1. Turn the rotary knob <PICTURE> to select the setting item you want to skip and press the rotary knob <PICTURE>.**

- The setting value can be changed.

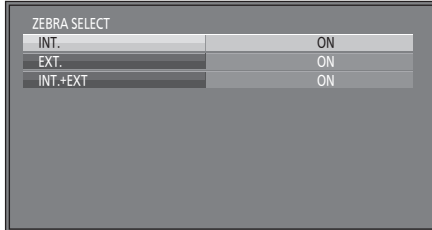

**2. Turn the rotary knob <PICTURE> to select [OFF] and press the rotary knob <PICTURE>.**

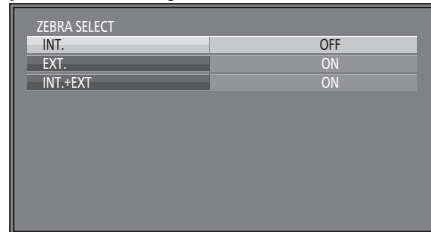

**3. Press <RETURN/VOLUME>.**

- The submenu closes and the [FUNCTION] menu reappears.

■ **SDI DISPLAY MODE function**

SDI DISPLAY MODE function allows you to select the display mode for SDI input video.

- When [SINGLE] is set, the selected input video is displayed over the entire screen.
- When [QUAD] is set, the entire screen is split into four areas and the input video of each of SDI1, SDI2, SDI3, and SDI4 is displayed in a separate area.

The display positions of SDI1, SDI2, SDI3, and SDI4 are fixed (SDI1 at top left, SDI2 at top right, SDI3 at bottom left, and SDI4 at bottom right).

<Note>

- When video is displayed while [QUAD] is set, inputs in the same format as the SDI1 input are displayed.
- The audio level meter and time code can be displayed for each input video when [QUAD] is set.
- Normal mode, [PICTURE ASSIST] mode, and [MULTI FUNCTION] mode are available when [QUAD] is set. For each mode, the display can be changed by turning the function on or off.
- When [QUAD] is set, a 4K signal cannot be displayed.

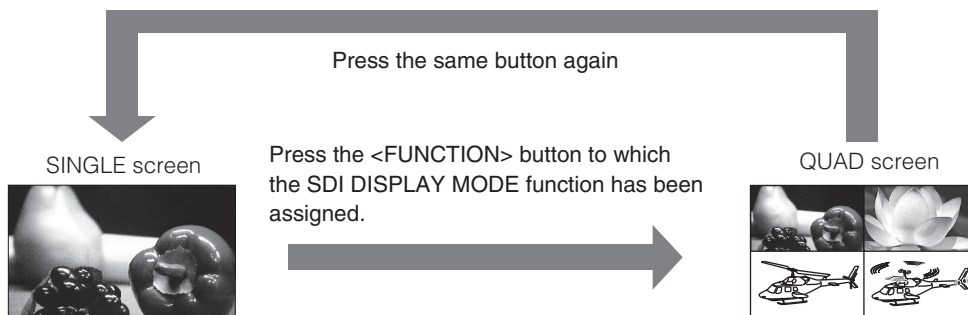

### PICTURE ASSIST function

The PICTURE ASSIST function displays the same input video on four screens.

Use this function to apply an effect in each screen while checking the video at the top left. This can be very helpful during shooting with the camera.

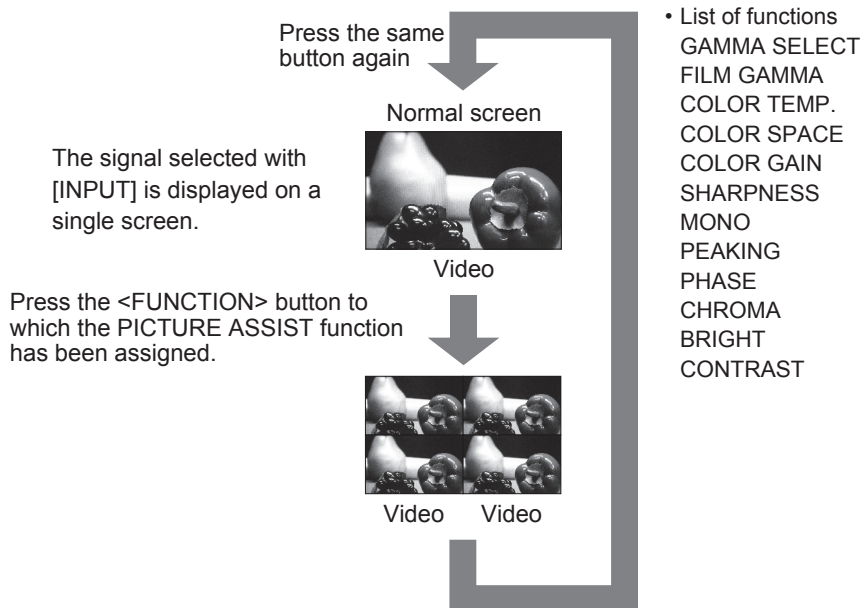

#### <Note>

- Select the screen to which to apply the effect in DISPLAY SELECT. (AREA2 indicates the top right screen, AREA3 indicates the bottom left screen, and AREA4 indicates the bottom right screen.)
- When the PICTURE ASSIST function is on and the Y MAP function is turned on while one of the [BLUE ONLY], [R COLOR], [G COLOR], and [B COLOR] functions is on, the [BLUE ONLY], [R COLOR], [G COLOR], and [B COLOR] effects cannot be applied to the other screens.
- When the PICTURE ASSIST function is turned on, BLACK MODE setting is turned off.
- When the PICTURE ASSIST function is turned on, the MULTI FUNCTION setting is turned off.
- When the PICTURE ASSIST function is turned on in SINGLE screen mode, SDI DISPLAY MODE also becomes QUAD at the same time. When the PICTURE ASSIST function is turned off later, SDI DISPLAY MODE also becomes SINGLE.
- When the PICTURE ASSIST function is turned on, the audio level meter and time code are not displayed.
- If the power is turned off while the PICTURE ASSIST function is on, the PICTURE ASSIST function will be off and the unit will start up in the QUAD state when the power is turned on the next time.

### MULTI FUNCTION function

Use the MULTI FUNCTION function to display FOCUS-IN-RED, WFM, and VSC simultaneously for the original image. (2K and HD signals only)

Each press of the <FUNCTION1> to <FUNCTION5> (→page 12) button with the MULTI FUNCTION function assigned changes the display.

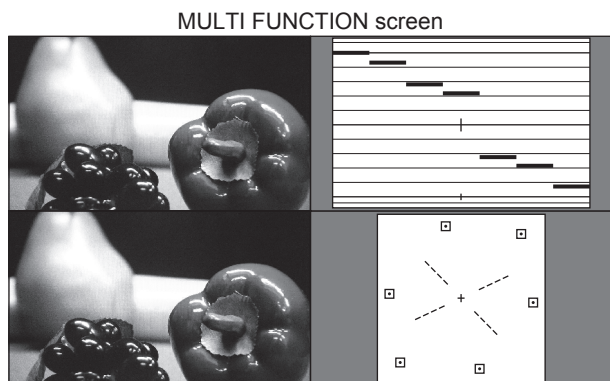

- Top left screen: Normal screen
- Top right screen: WFM screen
- Bottom left screen: FOCUS-IN-RED screen
- Bottom right screen: VECTOR screen

#### <Note>

- When the MULTI FUNCTION function is turned on, the PICTURE ASSIST setting is turned off.
- When the MULTI FUNCTION function is turned on in SINGLE screen mode, SDI DISPLAY MODE also becomes QUAD at the same time. When the MULTI FUNCTION function is turned off later, SDI DISPLAY MODE also becomes SINGLE.
- When the MULTI FUNCTION function is turned on, the YMAP setting is turned off.
- When the MULTI FUNCTION function is turned on, the FOCUS-IN-RED setting is also turned on.  
 Furthermore, when the MULTI FUNCTION function is turned off, the FOCUS-IN-RED setting is also turned off.
- When the MULTI FUNCTION function is turned on, the audio level meter and time code are displayed only in the top left area.

■ **WFM/VECTOR**

The WFM/VECTOR function allows you to display waveform and vector display screens. Set WFM display and VECTOR display in the [MEASURE SETUP] item of the [MAIN MENU] (main menu). (→page 30)

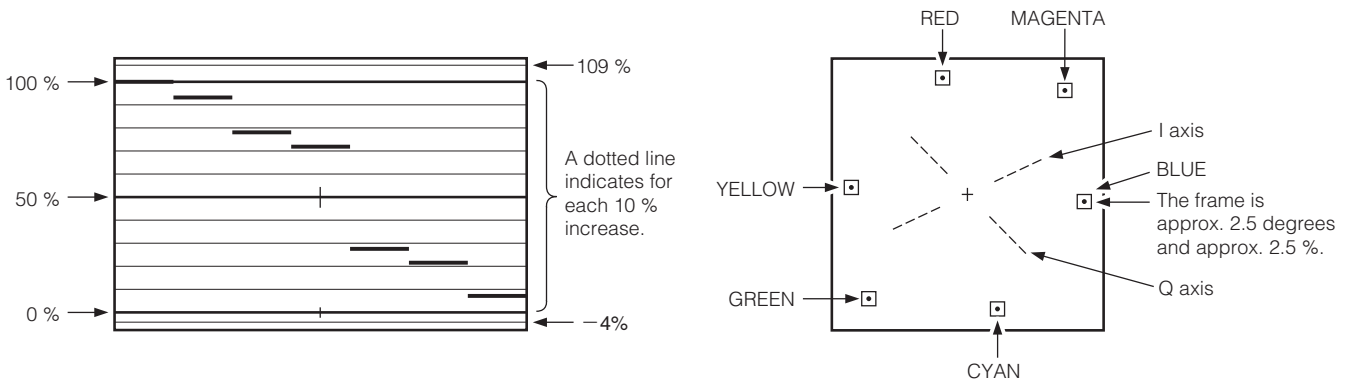

The horizontal lines in each frame are color coded to simplify identification.

<Note>

- The WFM/VECTOR display is shifted one line at a set interval to prevent temporary afterimage (burn-in).

■ **FRAME GRAB function**

The FRAME GRAB function stores the entire screen in the unit and displays it as a still image.

- The screen changes each time you press the <FUNCTION1> to <FUNCTION5> (→page 12) button with the FRAME GRAB function assigned.
- Use the FRAME GRAB function while a signal is being input. When the input signal is distorted, display may be distorted or some parts may not be displayed. Also, the function will be disabled if there is no signal or the operation to switch the signal format, switch the screen mode, or turn the power off is performed.

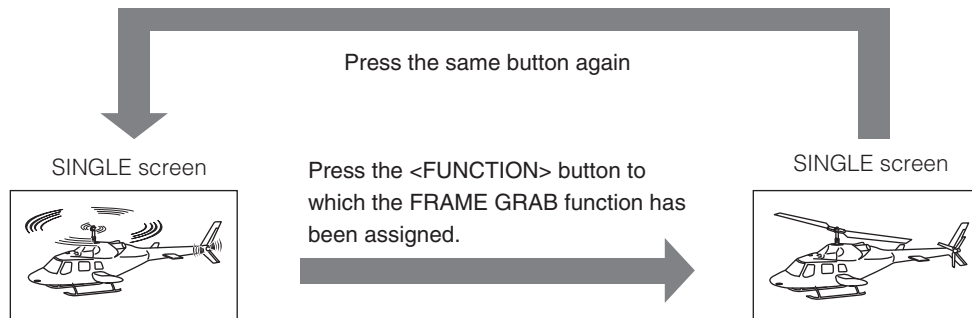

<Note>

- When FRAME GRAB is turned on/off, the AUDIO MUTE function is also turned on/off at the same time.
- This function is for when all of the inputs are the same format.  
If inputs of different formats are displayed, the display may be distorted or some parts may not be displayed.
- If a frame is grabbed when the time code is displayed, the time code also stops at the same time but the video and time code value do not match.
- When the FRAME GRAB function is turned on, some functions such as Y MAP do not work.

■ **ZOOM**

Use the ZOOM function to display a 4K signal in zoom mode. (4K signals only)

Set this in the [VIDEO CONFIG] item of [MAIN MENU] (main menu). (→page 28)

Press the <FUNCTION1> to <FUNCTION5> (→page 12) button with the ZOOM function assigned to change the display in the following order.

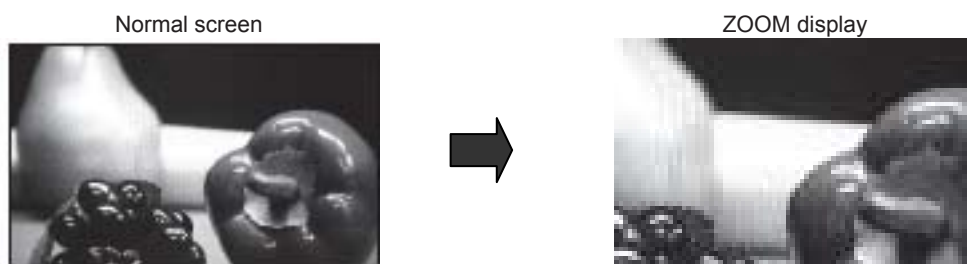

### ■ ZOOM POSITION display position sequence

Display position of ZOOM POSITION: ① → ② → ③ → ④ → ⑤ → ① → and so on

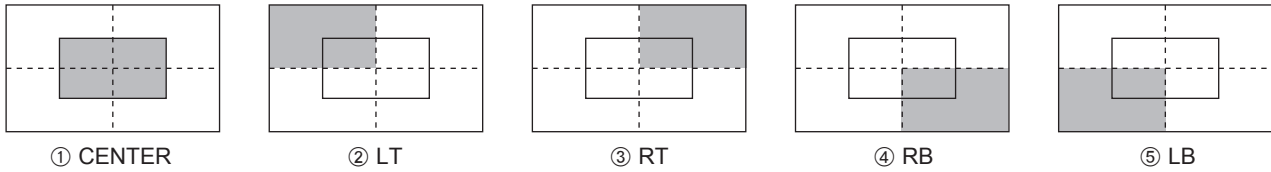

### ■ ZEBRA

The stripes of the ZEBRA function appear over an image (in the viewfinder) to help you adjust the aperture of a camera lens for optimum exposure and easily find the areas of an image that are overexposed and white (where clipping occurs).

Press the <FUNCTION1> to <FUNCTION5> (→page 12) button with [ZEBRA LEVEL] assigned in the [MEASURE SETUP] menu to set the [INT. MIN.], [INT. MAX.], [EXT. MIN.] and [EXT. MAX.] levels.

Press the <FUNCTION1> to <FUNCTION5> button with [ZEBRA] assigned to turn the ZEBRA function on.

[INT. MIN.] and [INT. MAX.] show ZEBRA stripes for areas within the range set in the menu.

[EXT. MIN.] and [EXT. MAX.] show ZEBRA stripes for areas outside the range set in the menu.

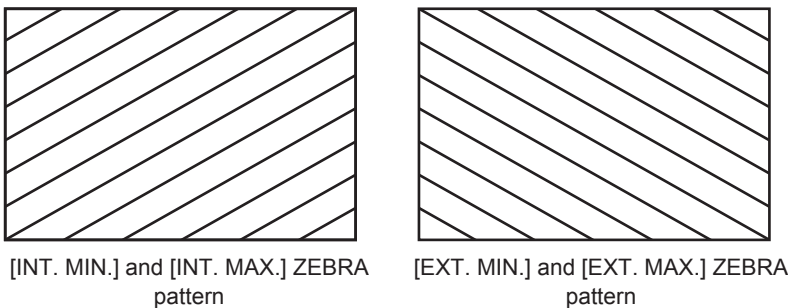

#### <Note>

- Black sections outside the image area may also be shown as ZEBRA stripes.
- The ZEBRA pattern may become offset by input selection or function operation.

### ■ Y MAP

The Y MAP function makes it easy to visually confirm the overall screen brightness (luminance level map).

Press the <FUNCTION1> to <FUNCTION5> (→page 12) button with [Y MAP] assigned to turn the function on.

Turning on this function displays a simplified chart at the left side of the screen.

- Simplified chart details (The numbers in the simplified chart indicate Y signal levels.)

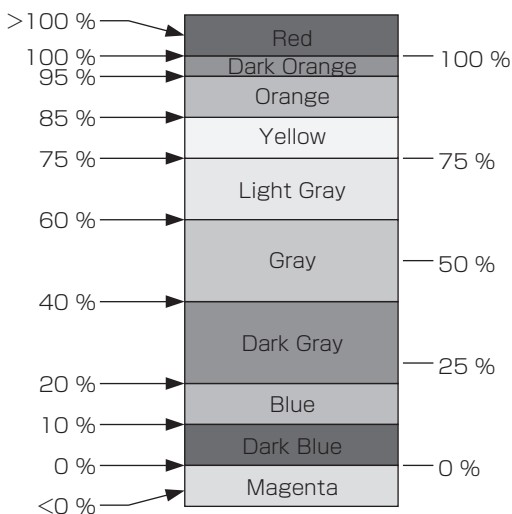

#### <Note>

- When [HALF] or [BLACK] is selected in the [BACK] item of the [MARKER] menu, the simplified chart indicates a signal level of 50 % or may not be displayed at all.
- When the Y MAP function is turned on, [BLACK MODE] is turned off.
- The black parts outside the image area may be displayed at 0 % (dark blue) or less than 0 % (magenta).

## Main Menu (Continued)

### ■ PIXEL TO PIXEL

The PIXEL TO PIXEL function allows you to check images at their actual pixel resolution. (Supported format: 1280×720p signal)  
The underlined values are the factory defaults.

Item	Setting	Description
PIXEL TO PIXEL *10	<u>OFF</u>	Sets whether to display the screen display size at the input signal size. [OFF] Not displayed [ON] Displayed.
	ON	

\*10 The following setting is disabled when [PIXEL TO PIXEL] is [ON].

- [MARKER] display

### ■ CROSS HATCH

The CROSS HATCH function displays markers at regular vertical and horizontal intervals to facilitate composition and other tasks. The marker line width is 1 dot per line and the interval is LARGE (240 dots/240 lines), MIDDLE (120 dots/120 lines), or SMALL (60 dots/60 lines) depending on the [SIZE] setting in the [MARKER] menu (→page 26).

Each press of the <FUNCTION1> to <FUNCTION5> (→page 12) button with the CROSS HATCH function assigned changes the display.

Each press of the <FUNCTION> button with the CROSS HATCH function assigned changes the display as shown below.

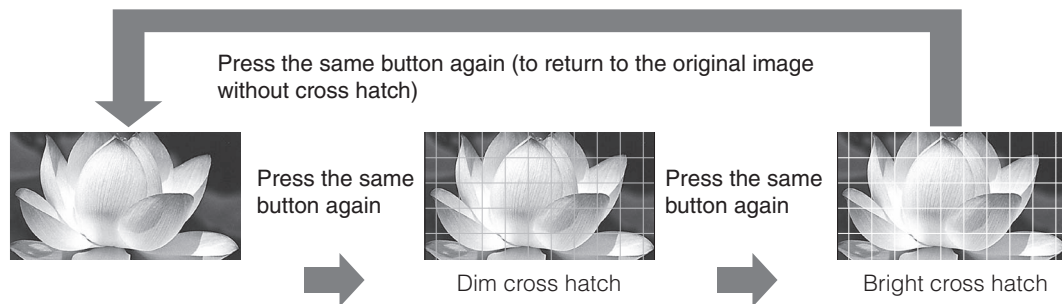

### ■ FOCUS-IN-RED

The FOCUS-IN-RED function displays the outline of the subject in focus in a color that simplifies focusing with the camera. Each press of the <FUNCTION1> to <FUNCTION5> button with the FOCUS-IN-RED function assigned changes the display.

- To use the FOCUS-IN-RED function, you need to assign it to one of <FUNCTION1> to <FUNCTION5>.

When the FOCUS-IN-RED function is displayed, use the rotary knob <PICTURE> to change the detection sensitivity level (1 to 30). A higher numerical value results in higher detection sensitivity (outlines are displayed in the set color even when they are not properly focused).

The outline color can be switched between RED, BLUE, and MONO in the [FOCUS-IN-RED COLOR] setting of the [MEASURE SETUP] menu (→page 30).

Also, from the [FOCUS-IN-RED MODE] setting, you can select NORMAL or PRECISE for the method of applying outlines.

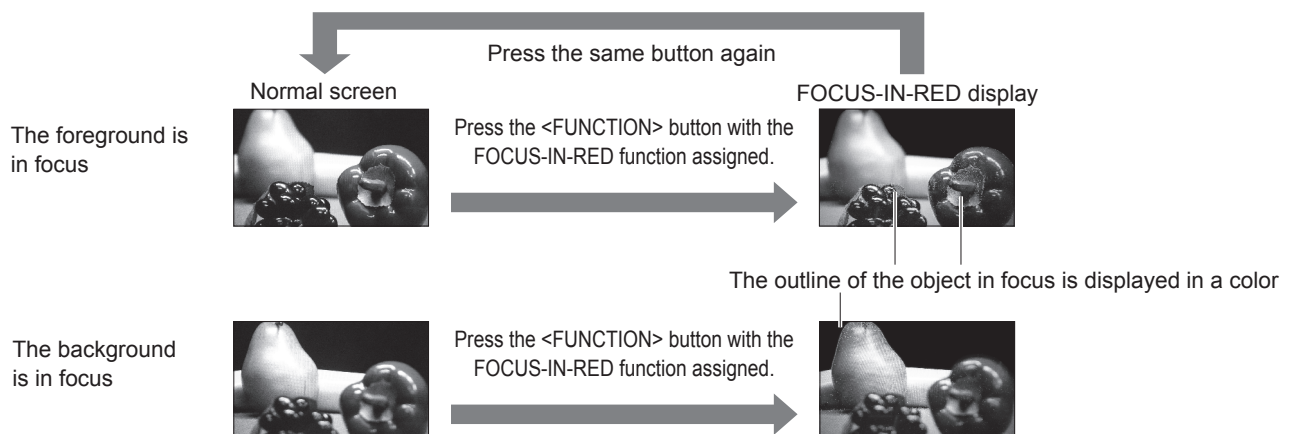

#### <Note>

- When you are using the PIXEL TO PIXEL or ZOOM function, the FOCUS-IN-RED function display may look slightly different than usual.

**AUDIO**

The underlined values are the factory defaults.

Submenu	Setting	Description
<b>GROUP SELECT</b>	<u>CH1-CH8</u> CH9-CH16	Selects the group of 16-channel audio in the SDI signal. [CH1-CH8] Displays channels 1 to 8. [CH9-CH16] Displays channels 9 to 16.
<b>SELECT L</b> *1 *2	CH1 to CH16 (Factory default: <u>CH1</u> )	Selects the embedded audio channels to output to the speaker or headphones (L).
<b>SELECT R</b> *1 *3	CH1 to CH16 (Factory default: <u>CH2</u> )	Selects the embedded audio channels to output to the speaker or headphones (R).
<b>SPEAKER OUT</b>	<u>MIX</u> L R	Selects the speaker output status. [MIX] Outputs a combination of the audio selected in [SELECT L] and [SELECT R]. [L] Outputs the audio selected in [SELECT L]. [R] Outputs the audio selected in [SELECT R].
<b>4K INPUT SELECT</b>		Selects the audio input for 4K signals (SDI [QUAD], DisplayPort [DUAL], or HDMI [DUAL]).
<b>SDI</b>	<u>SDI1</u> SDI2 SDI3 SDI4	Selects the audio input for when SDI input.
<b>DisplayPort</b>	<u>DisplayPort1</u> DisplayPort2	Selects the audio input for when DisplayPort input.
<b>HDMI</b>	<u>HDMI1</u> HDMI2	Selects the audio input for when HDMI input.

\*1 After a change of [GROUP SELECT] is confirmed, the change is reflected in the channel setting display of [SELECT L] and [SELECT R].

\*2 During HDMI/DisplayPort signal input, the audio of CH1 is output regardless of the menu setting.

\*3 During HDMI/DisplayPort signal input, the audio of CH2 is output regardless of the menu setting.



## DISPLAY SETUP

The underlined values are the factory defaults.

Submenu	Setting	Description
<b>TIME CODE</b>	<u>OFF</u> ON	Selects whether to enable or disable time code display.
<b>POSITION</b>	<u>LEFT</u> RIGHT	Selects the time code display position. [LEFT] Bottom left of screen [RIGHT] Bottom right of screen
<b>MODE SELECT</b>	<u>LTC</u> VTC LUB VUB LTC+LUB VTC+VUB	Selects the time code display mode. [LTC] Displays the linear time code. [VTC] Displays the vertical interval time code. [LUB] Displays the user bits included in LTC. [VUB] Displays the user bits included in VTC. [LTC + LUB] Displays [LTC] and [LUB] on two consecutive lines. [VTC + VUB] Displays [VTC] and [VUB] on two consecutive lines.
<b>CLOSED CAPTION</b>	<u>OFF</u> ON	Selects whether to enable or disable closed caption display.
<b>CC TYPE</b>	CEA-608(708) <u>CEA-708</u> OP-47	Selects the closed caption type. [CEA-608(708)] Displays CEA-608 standard data transmitted according to the CEA-708 standard. [CEA-708] Displays data compliant with CEA-708. [OP-47] Displays OP-47 data.
<b>CAPTION CHANNEL</b>	<u>CC1</u> CC2 CC3 CC4	Selects the closed caption display channel for when [CEA-608(708)].
<b>CAPTION SERVICE</b>	<u>SRV1</u> SRV2 SRV3 SRV4 SRV5 SRV6	Selects the closed caption display service for [CEA-708].
<b>AUDIO LEVEL METER</b>	<u>OFF</u> ON	Selects whether to display the audio level meter. (→page 18)
<b>CH SELECT</b>	2CH 4CH <u>8CH</u>	Selects the number of audio level meter channels. • 16 channels cannot be displayed simultaneously.
<b>POINT LINE</b>	OFF <u>ON</u>	Turns the 0 dB point and reference point in the meter display on or off.
<b>CH INFO.</b>	OFF <u>ON</u>	Switches the channel displayed in the meter display on or off.
<b>HEAD ROOM</b>	12dB <u>18dB</u> <u>20dB</u>	Sets the display position of the reference point in the meter display. • Factory default setting BT-4LH310P: 20dB BT-4LH310E: 18dB

**CONTROL**

The underlined values are the factory defaults.

Submenu	Setting	Description
<b>CONTROL</b>	<u>LOCAL</u> REMOTE	<p>Selects operation. (With control lock)</p> <p>[LOCAL] Enables front panel operation (including controls that use the GPI function).</p> <p>[REMOTE] Enables remote operation (control using RS-232C or RS-485; the front panel operation is locked).</p> <ul style="list-style-type: none"> <li>Powering on/off, VOLUME operations, GPI control, and menu display are available when the lock is engaged.</li> <li>Only the settings of the [CONTROL] and [LOCK ENABLE] menu items can be changed when the lock is engaged.</li> <li>The rotary knob &lt;PICTURE&gt; is disabled when the lock is engaged.</li> <li>Operation when the lock is engaged is in accordance with the [LOCK ENABLE] setting.</li> <li>The  mark is displayed in the operating status display, menu display ([MAIN MENU] (main menu), [FUNCTION] menu, and [INPUT SELECT] menu), [PICTURE] (picture adjustment) menu, and function display screens when the lock is engaged.</li> </ul> 
<b>LOCAL ENABLE</b> *1	<u>DISABLE</u> INPUT FUNCTION INPUT+FUNC.	<p>Selects whether to enable or disable the &lt;INPUT SELECT&gt; and &lt;FUNCTION&gt; button operations when [REMOTE] is selected in [CONTROL].</p> <p>[DISABLE] Disables the &lt;INPUT SELECT&gt; and &lt;FUNCTION&gt; button operations.</p> <p>[INPUT] Enables the &lt;INPUT SELECT&gt; button operation.</p> <p>[FUNCTION] Enables the &lt;FUNCTION&gt; button operation.</p> <p>[INPUT+FUNC.] Enables the &lt;INPUT SELECT&gt; and &lt;FUNCTION&gt; button operations.</p>
<b>GPI</b>		Displays GPI related menus.
<b>RS-485 ID SETUP</b>	0 to 126 (Factory default setting: 0)	Sets the ID number of the unit for communication using RS-485.

\*1 This is only available when [CONTROL] is [REMOTE].

■ GPI related

Submenu	Setting	Description
<b>GPI CONTROL</b>	<u>DISABLE</u> ENABLE	<p>Enables and disables the GPI functions.</p> <p>[DISABLE] Disables [ENABLE] Enables</p>
<b>GPI1 to GPI8</b>	UNDEF INPUT SDI INPUT DisplayPort DUAL INPUT DisplayPort SINGLE INPUT HDMI DUAL INPUT HDMI SINGLE INPUT INT-SG R-TALLY G-TALLY MONO	<p>Sets the PIN assignment of the GPI input connector.</p> <p>The items that can be set are the same for each terminal.</p> <p>(For details, refer to page 54)</p>



## Main Menu (Continued)

Submenu	Setting	Description
(Continued from the previous page)	GAMMA SEL. 2.20 GAMMA SEL. 2.40 GAMMA SEL. 2.60 GAMMA SEL. FILM GAMMA SEL. MANUAL SET PIXEL TO PIXEL FOCUS-IN-RED ZEBRA REMOTE STANDBY	

### <Note>

Operation may not be possible depending on the setting conditions.

Example: PIXEL TO PIXEL operation when the input signal is 4K

## INFORMATION

Submenu	Setting	Description
<b>HOURS METER</b>		Displays the total number of hours that have elapsed.
<b>SDI ERROR LOG</b>		Displays the SDI error log.

## HOURS METER

Submenu	Setting	Description
<b>OPERATION</b>	xxxxxxh *1	Displays the total number of hours the unit has been on.
<b>LCD</b>	xxxxxxh *1	Displays the number of hours the backlight has been on.

\*1 "xxxxxx" indicates up to 262800 hours (approximately 30 years). [OVER] is indicated when the number of hours is 262800 or higher.

## SDI ERROR LOG

Displays the log for SDI errors (CRCC errors and PAYLOAD ID errors).

### <Note>

- The SDI input connector and time code value are also displayed at the same time.
- Up to 10 logs can be saved, and the logs are deleted from the oldest when that number is exceeded.
- The logs are deleted when the power is turned off.
- Performing a reset turns off the status error display.

# Setting Item Restrictions

## ■ List of setting item restrictions

(✓: Can be set)

Setting item	Input terminal	SDI1/SDI2/SDI3/SDI4 DisplayPort1/DisplayPort2 HDMI1/HDMI2				DisplayPort1/ DisplayPort2 HDMI1/HDMI2	SDI1/SDI2/SDI3/SDI4		
	Format	4K		2K/HD		COMP.	2K/HD		
	Display state	SINGLE screen		SINGLE screen		SINGLE screen	QUAD screen		
		ZOOM		PIXEL TO PIXEL			MULTI FUNCTION	PICTURE ASSIST	
MARKER	MARKER	✓		✓					
	ASPECT1	✓		✓					
	ASPECT1 RATIO	✓		✓					
	ASPECT1 MODE (17:9)	✓		✓					
	ASPECT1 MODE (16:9)	✓		✓					
	AREA1	✓		✓					
	ASPECT2	✓		✓					
	ASPECT2 RATIO	✓		✓					
	ASPECT2 MODE (17:9)	✓		✓					
	ASPECT2 MODE (16:9)	✓		✓					
	AREA2	✓		✓					
	BACK	✓		✓					
	CENTER	✓		✓					
	CROSS	✓		✓					
	COLOR ITEM	✓		✓					
COLOR	✓		✓						
CROSS HATCH	✓		✓						
SIZE	✓		✓						
VIDEO CONFIG	GAMMA SELECT	✓	✓	✓	✓	✓	✓	✓	✓*1
	FILM GAMMA	✓	✓	✓	✓	✓	✓	✓	✓*1
	COLOR TEMP.	✓	✓	✓	✓	✓	✓	✓	✓*1
	VARn COLOR TEMP.	✓	✓	✓	✓	✓	✓	✓	✓*1
	GAIN RED					✓			
	GREEN					✓			
	BLUE					✓			
	BIAS RED					✓			
	GAIN					✓			
	BLUE					✓			
	RESET					✓			
	COLOR SPACE	✓	✓	✓	✓	✓	✓	✓	✓*1
	LUT	✓	✓	✓	✓	✓	✓	✓	✓*1
	COLOR GAIN RED	✓	✓	✓	✓	✓	✓	✓	✓*1
	GREEN	✓	✓	✓	✓	✓	✓	✓	✓*1
	BLUE	✓	✓	✓	✓	✓	✓	✓	✓*1
	SHARPNESS MODE	✓	✓	✓	✓	✓	✓	✓	✓*1
	SHARPNESS H	✓	✓	✓	✓	✓	✓	✓	✓*1
	SHARPNESS V	✓	✓	✓	✓	✓	✓	✓	✓*1
	MONO	✓	✓	✓	✓	✓	✓	✓	✓*1
ZOOM MODE	✓	✓			✓*2				
POSITION		✓			✓*2				
FRAME GRAB	✓	✓	✓	✓	✓				

\*1 This cannot be set for the top left image of the four screens. The factory default value is set.

\*2 Images of 3840x2160 or higher are supported.

(Continued on next page)

## Setting Item Restrictions (Continued)

(✓: Can be set)

Setting item	Input terminal	SDI1/SDI2/SDI3/SDI4 DisplayPort1/DisplayPort2 HDMI1/HDMI2				DisplayPort1/ DisplayPort2 HDMI1/HDMI2	SDI1/SDI2/SDI3/SDI4		
	Format	4K		2K/HD		COMP.	2K/HD		
	Display state	SINGLE screen		SINGLE screen		SINGLE screen	QUAD screen		
		ZOOM		PIXEL TO PIXEL			MULTI FUNCTION	PICTURE ASSIST	
MEASURE SETUP	FOCUS-IN-RED	✓	✓	✓	✓	✓	✓	✓*1*3	✓*4
	MODE	✓	✓	✓	✓	✓	✓	✓	✓*4
	COLOR	✓	✓	✓	✓	✓	✓	✓	✓*4
	Y MAP	✓	✓	✓	✓	✓	✓		✓*4
	ZEBRA	✓	✓	✓	✓	✓	✓		✓*4
	INT. MIN.	✓	✓	✓	✓	✓	✓		✓*4
	INT. MAX.	✓	✓	✓	✓	✓	✓		✓*4
	EXT. MIN.	✓	✓	✓	✓	✓	✓		✓*4
	EXT. MAX.	✓	✓	✓	✓	✓	✓		✓*4
	WFM							✓	
	LINE SELECT							✓	
	VECTOR MODE							✓	
	SCALE							✓	
	SYSTEM CONFIG	FORMAT					✓		
4K MODE		✓	✓			✓			
2K/HD MODE				✓	✓	✓	✓	✓	✓
1080i/PsF				✓	✓		✓	✓	✓
RANGE						✓			
SDI DISPLAY MODE				✓	✓		✓		
MENU POSITION						✓			
STATUS DISPLAY						✓			
CRCC ERROR		✓*5	✓*5	✓*5	✓*5		✓*5		
PAYLOAD ID ERROR		✓*5	✓*5	✓*5	✓*5		✓*5		
SDI REC TALLY				✓*6	✓*6		✓*6		
INPUT NAME SETUP						✓			
SETUP LOAD						✓			
SETUP SAVE						✓			
POWER ON SETUP						✓			
POWER DOWN						✓			
POWER SAVE MODE						✓			
LED BRIGHT					✓				
CALIBRATION					✓				
FUNCTION	FUNCTION1 to 5								
	SETUP					✓			
	FUNCTION DISPLAY								
AUDIO	GROUP SELECT	✓*5	✓*5	✓*5	✓*5		✓*7	✓	✓
	SELECT L	✓	✓	✓	✓		✓*7	✓	✓
	SELECT R	✓	✓	✓	✓		✓*7	✓	✓
	SPEAKER OUT	✓	✓	✓	✓		✓	✓	✓
	4K INPUT SELECT					✓			
	SDI	✓	✓						
	DisplayPort	✓	✓						
HDMI	✓	✓							

\*1 This cannot be set for the top left image of the four screens. The factory default value is set.

\*3 The setting is fixed at FOCUS IN RED for the bottom left image of the four screens.

\*4 This is set for all the images of the four screens.

\*5 This is set only for SDI.

\*6 This is set only for HD-SDI.

\*7 This is set for the SDI input selected in the [DISPLAY SELECT] function.

(Continued on next page)

## Setting Item Restrictions (Continued)

(✓: Can be set)

Setting item	Input terminal	SDI1/SDI2/SDI3/SDI4 DisplayPort1/DisplayPort2 HDMI1/HDMI2				DisplayPort1/ DisplayPort2 HDMI1/HDMI2	SDI1/SDI2/SDI3/SDI4	
	Format	4K		2K/HD		COMP.	2K/HD	
	Display state	SINGLE screen		SINGLE screen		SINGLE screen	QUAD screen	
		ZOOM		PIXEL TO PIXEL			MULTI FUNCTION	PICTURE ASSIST
DISPLAY SETUP	TIME CODE							
	POSITION							
	MODE SELECT							
	CLOSED CAPTION							
	CC TYPE							
	CAPTION CHANNEL	✓*5	✓*5	✓*5	✓*5		✓	
	CAPTION SERVICE							
	AUDIOLEVEL METER							
	CH SELECT							
	POINT LINE							
	CH INFO.							
	HEAD ROOM							
CONTROL	CONTROL							
	LOCK ENABLE							
	GPI	✓						
	RS-485 ID SETUP							
GPI	GPI CONTROL	✓						
	GPI1 to 8							
INFORMATION	HOURS METER							
	OPERATION							
	LCD	✓*8						
	SDI ERROR							
	1 to 10							
	RESET							

FUNCTION	BLUE ONLY	✓							
	GAMMA SELECT	Same as [GAMMA SELECT] menu							
	WHITE BALANCE	Same as [COLOR TEMP.] menu							
	MONO	Same as [MONO] menu							
	BLACK MODE	✓							
	R COLOR	✓							
	G COLOR	✓							
	B COLOR	✓							
	SDI DISPLAY MODE	Same as [SDI DISPLAY MODE] menu							
	ZOOM MODE	Same as [ZOOM MODE] menu							
	ZOOM POSITION	Same as [ZOOM POSITION] menu							
	PIXEL TO PIXEL			✓*9	✓*9				
	FRAME GRAB	Same as [FRAME GRAB] menu							
	DISPLAY SELECT						✓	✓	✓
	MULTI FUNCTION			✓*5	✓*5		✓	✓	✓
	PICTURE ASSIST			✓*5	✓*5				✓
	WFM LINE SELECT	Same as [LINE SELECT] menu							
	AUDIO MUTE	✓	✓	✓	✓		✓	✓	✓
	LEVEL METER	Same as [AUDIOLEVEL METER] menu							
	TIME CODE	Same as [TIME CODE] menu							
	CLOSED CAPTION	Same as [CLOSED CAPTION] menu							
	MARKER	Same as [MARKER] menu							
	FRAME MARKER	Same as [MARKER] menu							
	OUTER LINE MARKER	Same as [MARKER] menu							
	CROSS HATCH	Same as [MARKER] menu							

\*5 This is set only for SDI.

\*8 The data is updated when the SDI input image is displayed.

\*9 Only 1280x720p signals are supported.

(Continued on next page)

## Setting Item Restrictions (Continued)

(✓: Can be set)

Setting item	Input terminal	SDI1/SDI2/SDI3/SDI4 DisplayPort1/DisplayPort2 HDMI1/HDMI2		DisplayPort1/ DisplayPort2 HDMI1/HDMI2	SDI1/SDI2/SDI3/SDI4			
	Format	4K	2K/HD	COMP.	2K/HD			
	Display state	SINGLE screen	SINGLE screen	SINGLE screen	QUAD screen			
		ZOOM	PIXEL TO PIXEL		MULTI FUNCTION	PICTURE ASSIST		
FUNCTION	FOCUS-IN-RED	Same as [FOCUS-IN-RED] menu						
	Y MAP	Same as [Y MAP] menu						
	ZEBRA	Same as [ZEBRA] menu						
	ZEBRA LEVEL	Same as [ZEBRA] menu						
	SCREEN SAVER	✓						
	LUT	Same as [LUT] menu						
GPI	UNDEF	✓						
	INPUT SDI	✓						
	INPUT DisplayPort DUAL	✓						
	INPUT DisplayPort SINGLE	✓						
	INPUT HDMI DUAL	✓						
	INPUT HDMI SINGLE	✓						
	R-TALLY	✓						
	G-TALLY	✓						
	MONO	Same as [MONO] menu						
	GAMMA SEL. 2.20	Same as [GAMMA SELECT] menu						
	GAMMA SEL. 2.40							
	GAMMA SEL. 2.60							
	GAMMA SEL. FILM							
	GAMMA SEL. MANUAL SET							
	PIXEL TO PIXEL	Same as [PIXEL TO PIXEL] function						
FOCUS-IN-RED	Same as [FOCUS-IN-RED] menu							
ZEBRA	Same as [ZEBRA] menu							
REMOTE STANDBY	✓							
PICTURE	SETTING [LAST]	✓						
	PEAKING							
	PHASE							
	CHROMA							
	BRIGHT							
	CONTRAST							
	BACKLIGHT							
	FOCUS-IN-RED							
VOLUME	VOLUME	✓	✓	✓	✓	✓	✓	✓

# REMOTE Specifications

This unit can be operated externally via the GPI input connector, the RS-232C input connector, or the RS-485 input/output connectors.

## GPI Input Connector

GPI screen items correspond to the following terminals. Assign a function to each terminal in the GPI screen of the menu. (→page 48) The function assigned to each terminal is executed as specified depending on whether GND (pin 5) is short-circuited (ON) or open (OFF).

### ■ Operating conditions

Level operation: Operates when GND is short-circuited.

Edge operation: Operates when GND changes from open to short-circuited.

#### <Note>

- When level operation is assigned to more than one terminal, the function operates while any of the terminals is short-circuited.
- Hold the edge operation for at least 0.2 seconds after the change.

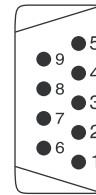

GPI input connector  
(9 pins)

Pin number	Signal
1	GPI1
2	GPI2
3	GPI3
4	GPI4
5	GND
6	GPI5
7	GPI6
8	GPI7
9	GPI8

Assigned item	Function	Operating conditions
<b>INPUT SDI</b>	Switches the input line to SDI.*1	Edge operation
<b>INPUT DisplayPort DUAL</b>	Switches the input line to DisplayPort DUAL.*1	Edge operation
<b>INPUT DisplayPort SINGLE</b>	Switches the input line to DisplayPort SINGLE.*1	Edge operation
<b>INPUT HDMI DUAL</b>	Switches the input line to HDMI DUAL.*1	Edge operation
<b>INPUT HDMI SINGLE</b>	Switches the input line to HDMI SINGLE.*1	Edge operation
<b>INPUT INT-SG</b>	Switches the input line to INT-SG.*1	Edge operation
<b>R-TALLY *2</b>	Lights the red tally.	Level operation (Short-circuited: ON, Open: OFF)
<b>G-TALLY *2</b>	Lights the green tally.	Level operation (Short-circuited: ON, Open: OFF)
<b>MONO</b>	Enables or disables monochrome display.	Level operation (Short-circuited: ON, Open: OFF)
<b>GAMMA SEL.2.20</b>	Switches the gamma characteristic to 2.20.	Level operation (Short-circuited: ON, Open: OFF)
<b>GAMMA SEL.2.40</b>	Switches the gamma characteristic to 2.40.	Level operation (Short-circuited: ON, Open: OFF)
<b>GAMMA SEL.2.60</b>	Switches the gamma characteristic to 2.60.	Level operation (Short-circuited: ON, Open: OFF)
<b>GAMMA SEL.FILM</b>	Switches the gamma characteristic to FILM.	Level operation (Short-circuited: ON, Open: OFF)
<b>GAMMA SEL.MANUAL SET</b>	Switches the gamma characteristic to MANUAL SET.	Level operation (Short-circuited: ON, Open: OFF)
<b>PIXEL TO PIXEL</b>	Switches the screen display between input size and display size.	Level operation (Short-circuited: ON, Open: OFF)
<b>FOCUS-IN-RED</b>	Displays the outlines of the subject in focus in red or another color.	Level operation (Short-circuited: ON, Open: OFF)
<b>ZEBRA</b>	Superimposes the ZEBRA pattern over the image with a specified brightness signal level.	Level operation (Short-circuited: ON, Open: OFF)
<b>REMOTE STANDBY*3*4</b>	Sets remote standby (turns off the backlight).	Level operation (Short-circuited: ON, Open: OFF)

\*1 The operation is the same as that performed with the front button.

\*2 When [R-TALLY] and [G-TALLY] turn on simultaneously, the tally color is amber.

\*3 When remote standby is set to ON, the power lamp on the front panel flashes.

\*4 If you use a menu to set this function after short-circuiting the GPI input connector to which it will be assigned, the backlight turns off and the screen display goes blank making it impossible to check the menu operation. To change the setting of this item, be sure to set it when the GPI input connector is in the open state.

### Restrictions

- The same as the restrictions for FUNCTION operations.
- The restrictions for INPUT operations are the same as for INPUT SELECT on the front.

## REMOTE Specifications (Continued)

### Priority of assigned items

- When [GAMMA SEL. 2.20], [GAMMA SEL. 2.40], [GAMMA SEL. 2.60], [GAMMA SEL. FILM], and [GAMMA SEL. MANUAL SET] are [ON] at the same time, [GAMMA SEL. 2.20] takes priority. The mode priority order is [GAMMA SEL. 2.20] > [GAMMA SEL. 2.40] > [GAMMA SEL. 2.60] > [GAMMA SEL. FILM] > [GAMMA SEL. MANUAL SET]. The gamma is 2.35 when none of the GAMMA SEL items is selected.

## RS-232C Input Connector

The unit can be operated externally via the RS-232C interface.

For details on the pin arrangement and connection of the RS-232C input connector, refer to the diagram below and the tables on the right below.

For details on specific systems using RS-232C input connectors, contact your supplier.

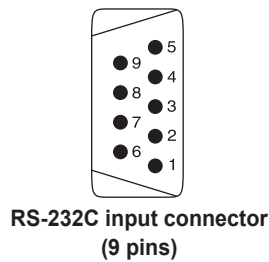

External device side		(Straight)	Device side	
Pin number	Signal		Pin number	Signal
1	N.C.		1	N.C.
2	RXD	←	2	TXD
3	TXD	→	3	RXD
4	DTR	→	4	DSR
5	GND	→	5	GND
6	DSR	←	6	DTR
7	RTS	→	7	CTS
8	CTS	←	8	RTS
9	N.C.		9	N.C.

### Connectors and signals

Connector: D-SUB 9-pin (female)

Signal

Pin number	Signal	Description
1	N.C.	Not connected
2	TXD	Transmission data
3	RXD	Reception data
4	DSR	Connected inside
5	GND	Ground
6	DTR	Connected inside
7	CTS	Connected inside
8	RTS	Connected inside
9	N.C.	Not connected

### Communication parameters

Signal level	RS-232C compliant
Synchronous system	Asynchronous system
Transfer rate	9 600 bps
Parity	None
Data length	8 bit
Stop bit	1 bit
Flow control	None

### Command format

STX (02h)	Command	:	Data	ETX (03h)
-----------	---------	---	------	-----------

- The command is a 3-character string starting with STX and ending with ETX.
- Append any data after the colon (:) following the command, as required.

### Response formats

#### 1. Setting command response

STX (02h)	Command	ETX (03h)
-----------	---------	-----------

#### 2. Query command response

STX (02h)	Data	ETX (03h)
-----------	------	-----------

#### 3. Error response

STX (02h)	Error codes	ETX (03h)
-----------	-------------	-----------

Error codes

ER001: Invalid command

ER002: Parameter error

**RS-485 Input/Output Connectors**

The unit can be operated externally via the RS-485 interface. Refer to the figures below for the pin arrangement and connection of the RS-485 input/output connectors. For details on specific systems using RS-485 input/output connectors, contact your supplier.

Connection example

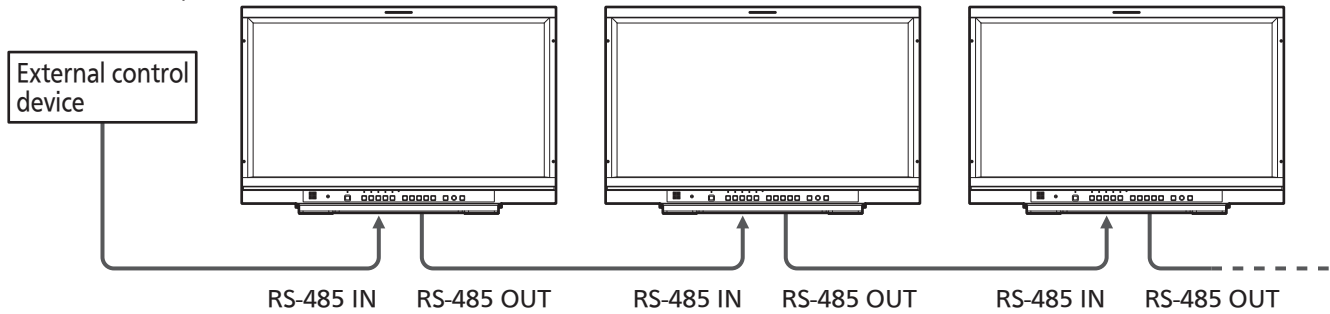

- A daisy chain connection using the RS-485 input/output connectors enables the control of multiple monitors (up to 32 monitors).
- Connect a terminating resistor (120 Ω) between the first and second pin of the OUT connector on the last monitor in the chain.

**Connectors and signals**

Connector: 8-pin RJ-45 connector



Pin number		Signal	Description
IN (input)	OUT (output)		
1	3	RXD+	Received data (+)
2	6	RXD-	Received data (-)
3	1	TXD+	Send data (+)
4	4	N.C.	Not connected
5	5	N.C.	Not connected
6	2	TXD-	Send data (-)
7	7	N.C.	Not connected
8	8	GND	Ground

**Communication parameters**

Synchronous system	Asynchronous system
Transfer rate	38 400 bps
Parity	EVEN
Data length	8 bit
Stop bit	1 bit
Flow control	None

**Command format**

STX (02h)	Header (ID)	Command	Data	EXT (03h)
-----------	-------------	---------	------	-----------

The header (ID) is 8-bit data. Set this in the [RS-485 ID SETUP] item of the [SYSTEM CONFIG] menu. When 0 is set in [RS-485 ID SETUP], multiple connected monitors can be controlled.

**Response formats**

**1. Setting command response**

STX (02h)	Command	EXT (03h)
-----------	---------	-----------

**2. Query command response**

STX (02h)	Data	EXT (03h)
-----------	------	-----------

**3. Error response**

STX (02h)	Error codes	EXT (03h)
-----------	-------------	-----------

Error codes  
 ER001: Invalid command  
 ER002: Parameter error

When 0 is set in [RS-485 ID SETUP], operation is enabled but responses are not.

After receiving a monitor response command, there should be a time lag of approx. 200 ms before a command is transmitted from an external control device.



## REMOTE Specifications (Continued)

### ■ Setting command

No.	Send commands	Command name	Data	Return
1	IIS:<data>	INPUT SELECT	00: SDI1    01: SDI2    08: HDMI1    09: INT-SG 10: HDMI2    11: SDI3    12: SDI4 13: DisplayPort1    14: DisplayPort2 15: HDMI DUAL    16: DisplayPort DUAL	IIS
2	VPC: CON<data>	CONTRAST	000 to 100	VPC
3	VPC: BRI<data>	BRIGHT	000 to 100	VPC
4	VPC: CRO<data>	CHROMA	000 to 100	VPC
5	VPC: PHA<data>	PHASE	000 to 100	VPC
6	VPC: VOL<data>	VOLUME	00 to 60	VOL
7	VBL: <data>	BACKLIGHT	000 to 200	VBL
8	DMK:MKC<data>	MARKER	0: OFF    1: ON	DMK
9	DMK: AS1<data>	ASPECT1	0: OFF    1: ON	DMK
10	DMK:AR1<data>	ASPECT1 RATIO	0: 17:9    1: 16:9	DMK
11	DMK: A11<data>	ASPECT1 MODE 17:9	00: 17:9    01: 16:9    02: 4:3    03: 13:9    04: 14:9 05: CNSCO2.35    06: CNSCO2.39    07: 2:1    08: VISTA	DMK
12	DMK: A12<data>	ASPECT1 MODE 16:9	01: 16:9    02: 4:3    03: 13:9    04: 14:9 05: CNSCO2.35    06: CNSCO2.39    07: 2:1    08: VISTA	DMK
13	DMK: AM1<data>	AREA1 MARKER	00: OFF    01: 80 %    02: 88 %    03: 93 % 04: 95 %    08: 90 % 080 to 100: USER80 % to 100 % xxxxyy: VAR.H.80 % to 100 %    V.80 % to 100 % (xxx: 080 to 100    yyy: 080 to 100) hhhhjjjjvwww:DOT LINE (hhhh/jjjj: 0000 to 4094    vwww/www: 0000 to 2158)	DMK
14	DMK: AS2<data>	ASPECT2	Same as ASPECT1	DMK
15	DMK: AR2<data>	ASPECT2 RATIO	Same as ASPECT1	DMK
16	DMK: A21<data>	ASPECT2 MODE 17:9	Same as ASPECT1	DMK
17	DMK: A22<data>	ASPECT2 MODE 16:9	Same as ASPECT1	DMK
18	DMK: AM2<data>	AREA2 MARKER	Same as AREA1	DMK
19	DMK:BAK<data>	MARKER BACK	0: NORMAL    1: HALF    2: BLACK	DMK
20	DMK:CMK<data>	CENTER MARKER	0: OFF    1: ON	DMK
21	DMK:VMK<data>	CROSS MARKER	xxxxyyyy: Position range    00000000(off) (xxxx: 0020 to 4075    yyyy: 0020 to 2139)	DMK
22	DMK:MCO<data>	MARKER COLOR	xy: Marker color x: Marker type    0: ASPECT1 AREA1    1: ASPECT2 AREA2 2: CENTER            3: CROSS y: Color        0: WHITE    1: BLACK    2: RED    3: GREEN 4: BLUE	DMK
23	DCH:<data>	CROSS HATCH	0: OFF    1: LOW    2: HIGH	DCH
24	DCW:<data>	CROSS HATCH SIZE	0: SMALL    1: LARGE    2: MIDDLE	DCW
25	MGM:<data>	GAMMA SELECT	1: 2.20    2: 2.35    3: 2.40    4: 2.60    5: FILM xxx:100 to 300( MANUAL SET, 005 increments)	MGM
26	MCT:<data>	COLOR TEMP	00: D56    01: D65    02: D93    03: VAR1    04: VAR2 05: VAR3    06: D63    07: D60    08: CINEMA 10 to 73: USER0 to 63	MCT
27	VWB:RGN<data>	WHITE BALANCE (R GAIN)	0000 to 1023    RED GAIN setting	VWB
28	VWB:GGN<data>	WHITE BALANCE (G GAIN)	0000 to 1023    GREEN GAIN setting	VWB

(Continued on next page)

## REMOTE Specifications (Continued)

No.	Send commands	Command name	Data	Return
29	VWB:BGN<data>	WHITE BALANCE (B GAIN)	0000 to 1023 BLUE GAIN setting	VWB
30	VWB:RBS<data>	WHITE BALANCE (R BIAS)	0000 to 1023 RED BIAS setting -512 to 511	VWB
31	VWB:GBS<data>	WHITE BALANCE (G BIAS)	0000 to 1023 GREEN BIAS setting -512 to 511	VWB
32	VWB:BBS<data>	WHITE BALANCE (B BIAS)	0000 to 1023 BLUE BIAS setting -512 to 511	VWB
33	SCS:<data>	COLOR SPACE	0: SMPTE-C 1: EBU 2: ITU-709 3: DCI-P3 7: NATIVE	SCS
34	VPC:SHP<data>	SHARPNESS MODE	0: LOW 1: HIGH	VPC
35	VPC:SHH<data>	SHARPNESS H	00 to 60: Horizontal sharpness setting	VPC
36	VPC:SHV<data>	SHARPNESS V	00 to 60: Vertical sharpness setting	VPC
37	OMO:<data>	MONO	1: OFF 2: ON	OMO
38	ZOM:<data>	ZOOM MODE	0: OFF 1: ON	ZOM
39	ZMP:<data>	ZOOM MODE POSITION	0: CENTER 1: LT 2: RT 3: RB 4: LB	ZMP
40	FGB:<data>	FRAME GRAB	0: OFF 1: ON	FGB
41	MFR:<data>	FOCUS IN RED	0: OFF 1: ON	MFR
42	MFM:<data>	FOCUS IN RED MODE	0: NORMAL 1: PRECISE	MFM
43	MFC:<data>	FOCUS IN RED COLOR	0: RED 1: BLUE 2: MONO	MFC
44	OYM:<data>	Y MAP	0: OFF 1: ON	OYM
45	OZB:<data>	ZEBRA	0: OFF 1: INT. 2: EXT. 3: INT.+EXT.	OZB
46	OZI:<data>	ZEBRA LEVEL INT.	XXXXYY: INT. range (-07 to 000 to 109) XXX: MIN value YYY: MAX value	OZI
47	OZE:<data>	ZEBRA LEVEL EXT.	XXXXYY: EXT. range (-07 to 000 to 109) XXX: MIN value YYY: MAX value	OZE
48	DWS:<data>	WFM SELECT	0: WFM Y 1: WFM R 2: WFM G 3: WFM B	DWS
49	DWL:<data>	WFM MODE	0000: ALL XXXX: LINE XXXX: Display line value	DWL
50	DIS:VMO<data>	VECTOR MODE	0: x1 1: x2S 2: x2 3: x4 4: x8	DIS
51	DIS:VSC<data>	VECTOR SCALE	0: 100% 1: 75%	DIS
52	DSD:<data>	STATUS DISP	0: CONTINUE 1: 3SEC OFF 2: OFF	DSD
53	AUD:GSL<data>	GROUP SELECT	0: 1 to 8 1: 9 to 16	AUD
54	AUD:ISL<data>	SELECT L	0: 1ch/9ch 1: 2ch/10ch 2: 3ch/11ch 3: 4ch/12ch 4: 5ch/13ch 5: 6ch/14ch 6: 7ch/15ch 7: 8ch/16ch	AUD
55	AUD:ISR<data>	SELECT R	0: 1ch/9ch 1: 2ch/10ch 2: 3ch/11ch 3: 4ch/12ch 4: 5ch/13ch 5: 6ch/14ch 6: 7ch/15ch 7: 8ch/16ch	AUD
56	AUD:ISS<data>	4K AUDIO INPUT SELECT SDI	0: SDI1 1: SDI2 2: SDI3 3: SDI4	AUD
57	AUD:ISD<data>	4K AUDIO INPUT SELECT DisplayPort	0: DisplayPort1 1: DisplayPort2	AUD
58	AUD:ISH<data>	4K AUDIO INPUT SELECT HDMI	0: HDMI1 1: HDMI2	AUD
59	DIS:TMP<data>	TIMECODE POSITION	1: RIGHT 3: LEFT	DIS
60	MCO:<data>	CONTROL	0: LOCAL 1: REMOTE	MCO
61	MLE:<data>	LOCAL ENABLE	0: DISABLE 1: INPUT 2: FUNCTION 3: INPUT+FUNC.	MLE
62	OBO:<data>	BLUE ONLY	0: OFF 1: ON	OBO
63	MBM:<data>	BLACK MODE	0: OFF 1: ON	MBM
64	ORC:<data>	R COLOR	0: OFF 1: ON	ORC
65	OGC:<data>	G COLOR	0: OFF 1: ON	OGC
66	OBC:<data>	B COLOR	0: OFF 1: ON	OBC

(Continued on next page)

## REMOTE Specifications (Continued)

No.	Send commands	Command name	Data	Return
67	DSP:<data>	SDI DISPLAY MODE	0: SINGLE 1: QUAD	DSP
68	MPP:<data>	PIXEL TO PIXEL	0: OFF 1: ON	MPP
69	ODS:<data>	DISPLAY SELECT	[For QUAD] 0: SDI1 1: SDI2 2: SDI3 3: SDI4 [For PICTURE ASSIST] 1: AREA2 2: AREA3 3: AREA4	ODS
70	OFC:<data>*1	MULTI FUNCTION	0: OFF 1: ON	OFC
71	OPA:<data>*1	PICTURE ASSIST	0: OFF 1: ON	OPA
72	AMT:<data>	AUDIO MUTE	0: OFF 1: ON	AMT
73	DLM:<data>	LEVEL METER	0: OFF 1: 2ch 2: 4ch 3: 8ch	DLM
74	DTM:<data>	TIME CODE	0: OFF 1: LTC 2: VTC 3: LUB 4: VUB 5: LTC+LUB 6: VTC+VUB	DTM
75	MCC:<data>*2	CLOSED CAPTION	00: OFF 05: SRV1(CEA-708) 06: SRV2(CEA-708) 07: SRV3(CEA-708) 08: SRV4(CEA-708) 09: SRV5(CEA-708) 10: SRV6(CEA-708) 12: OP-47 17: CC1 (CEA-608(708)) 18: CC2 (CEA-608(708)) 19: CC3 (CEA-608(708)) 20: CC4 (CEA-608(708))	MCC
76	FMK:<data>	FRAME MARKER	0: OFF 1: ON	FMK
77	FOM:<data>	OUTER LINE MARKER	0: OFF 1: ON	FOM
78	SSV:<data>	SCREEN SAVER	0: OFF 1: ON	SSV

\*1 With a SDI QUAD line (MULTI FUNCTION/PICTURE ASSIST) command, priority is given to switching to the mode input by command input.

(When this is switched to OFF, the mode becomes QUAD screen.)

\*2 Configures settings for the CLOSED CAPTION, CC TYPE, CAPTION CHANNEL, CAPTION SERVICE menu items of DISPLAY SETUP simultaneously.

## REMOTE Specifications (Continued)

### ■ Query commands

No.	Command parameter	Description	Response data
1	QIS	INPUT SELECT	00: SDI1    01: SDI2    11: HDMI1    12: INT-SG 13: SDI3    14: SDI4    15: HDMI2    16: DisplayPort1 17: DisplayPort2    18: HDMI DUAL 19: DisplayPort DUAL
2	QPC:CON	CONTRAST	000 to 100
3	QPC:BRI	BRIGHT	000 to 100
4	QPC:CRO	CHROMA	000 to 100
5	QPC:PHA	PHASE	000 to 100
6	QPC:VOL	VOLUME	00 to 60
7	QBL	BACKLIGHT	000 to 200
8	QMK:MKC	MARKER	0: OFF    1: ON
9	QMK:AS1	ASPECT1	0: OFF    1: ON
10	QMK:AR1	ASPECT1 RATIO	0: 17:9    1: 16:9
11	QMK:A11	ASPECT1 MODE 17:9	00: 17:9    01: 16:9    02: 4:3    03: 13:9    04: 14:9 05: CNSCO2.35    06: CNSCO2.39    07: 2:1    08: VISTA
12	QMK:A12	ASPECT1 MODE 16:9	01: 16:9    02: 4:3    03: 13:9    04: 14:9 05: CNSCO2.35    06: CNSCO2.39    07: 2:1    08: VISTA
13	QMK:AM1	AREA1 MARKER	00: OFF    01: 80 %    02: 88 %    03: 93 %    04: 95 % 08: 90 % 080 to 100: USER80 % to 100 % xxxyyy: VAR.H.80 % to 100%    V.80 % to 100 % (xxx: 080 to 100    yyy: 080 to 100) hhhhjjjjvvvvwwww: DOT LINE (hhhh/jjjj: 0000 to 4094    vvvv/www: 0000 to 2158)
14	QMK:AS2	ASPECT2	Same as ASPECT1
15	QMK:AR2	ASPECT2 RATIO	Same as ASPECT1
16	QMK:A21	ASPECT2 MODE 17:9	Same as ASPECT1
17	QMK:A22	ASPECT2 MODE 16:9	Same as ASPECT1
18	QMK:AM2	AREA2 MARKER	Same as AREA1
19	QMK:BAK	MARKER BACK	0: NORMAL    1: HALF    2: BLACK
20	QMK:CMK	CENTER MARKER	0: OFF    1: ON
21	QMK:VMK	CROSS MARKER	xxxxyyyy: Position range    00000000(off) (xxxx: 0020 to 4075    yyyy: 0020 to 2139)
22	QMK:COL	MARKER COLOR	wxyz: Color of each marker w: ASPECT1AREA1    x: ASPECT2 AREA2    y: CENTER    z: CROSS 0: WHITE    1: BLACK    2: RED    3: GREEN    4: BLUE
23	QCH	CROSS HATCH	0: OFF    1: LOW    2: HIGH
24	QCW	CROSS HATCH SIZE	0: SMALL    1: LARGE    2: MIDDLE
25	QGM	GAMMA SELECT	1: 2.20    2: 2.35    3: 2.40    4: 2.60    5: FILM xxx: 100 to 300 (MANUAL SET, 005 increments)
26	QCT	COLOR TEMP	00: D56    01: D65    02: D93    03: VAR1    04: VAR2    05: VAR3 06: D63    07: D60    08: CINEMA    10 to 73: USER0 to 63
27	QWB:RGN	WHITE BALANCE R-GAIN	0000 to 1023: RED GAIN setting value
28	QWB:GGN	WHITE BALANCE G-GAIN	0000 to 1023: GREEN GAIN setting value
29	QWB:BGN	WHITE BALANCE B-GAIN	0000 to 1023: BLUE GAIN setting value
30	QWB:RBS	WHITE BALANCE R-BIAS	0000 to 1023: RED BIAS setting value -512 to 511
31	QWB:GBS	WHITE BALANCE G-BIAS	0000 to 1023: GREEN BIAS setting value-512 to 511
32	QWB:BBS	WHITE BALANCE B-BIAS	0000 to 1023: BLUE BIAS setting value -512 to 511

(Continued on next page)

## REMOTE Specifications (Continued)

No.	Command parameter	Description	Response data
33	QCS	COLOR SPACE	0: SMPTE-C 1: EBU 2: ITU-709 3: DCI-P3 7: NATIVE
34	QPC:SHP	SHARPNESS MODE	0: LOW 1: HIGH 2: MIDDLE
35	QPC:SHH	SHARPNESS H	00 to 60: Horizontal sharpness setting value
36	QPC:SHV	SHARPNESS V	00 to 60: Vertical sharpness setting value
37	QMO	MONO	1: OFF 2: ON
38	QZM	ZOOM MODE	0: OFF 1: ON
39	QZP	ZOOM MODE POSITION	0: CENTER 1: LT 2: RT 3: LB 4: RB
40	QFG	FRAME GRAB	0: OFF 1: ON
41	QFI	FOCUS IN RED	0: OFF 1: ON
42	QFM	FOCUS IN RED MODE	0: NORMAL 1: PRECISE
43	QFC	FOCUS IN RED COLOR	0: RED 1: BLUE 2: MONO
44	QYM	Y MAP	0: OFF 1: ON
45	QZB	ZEBRA	0: OFF 1: INT. 2: EXT. 3: INT.+EXT.
46	QZI	ZEBRA LEVEL INT.	XXXXYY: INT. range (-07 to 000 to 109) XXX: MIN value YYY: MAX value
47	QZE	ZEBRA LEVEL EXT.	XXXXYY: EXT. range (-07 to 000 to 109) XXX: MIN value YYY: MAX value
48	QWS	WFM	1: WFM Y 2: WFM R 3: WFM G 4: WFM B
49	QWM	WFM MODE	0000: ALL XXXX: LINE XXXX: Display line value
50	QVM	VECTOR MODE	0: x1 1: x2S 2: x2 3: x4 4: x8
51	QVS	VECTOR SCALE	0: 100% 1: 75%
52	QTP	TIMECODE POSITION	1: RIGHT 3: LEFT
53	QGS	GROUP SELECT	0: 1 to 8 1: 9 to 16
54	QSL	SELECT L	0: 1ch/9ch 1: 2ch/10ch 2: 3ch/11ch 3: 4ch/12ch 4: 5ch/13ch 5: 6ch/14ch 6: 7ch/15ch 7: 8ch/16ch
55	QSR	SELECT R	0: 1ch/9ch 1: 2ch/10ch 2: 3ch/11ch 3: 4ch/12ch 4: 5ch/13ch 5: 6ch/14ch 6: 7ch/15ch 7: 8ch/16ch
56	QSS	4K AUDIO INPUT SELECT SDI	0: SDI1 1: SDI2 2: SDI3 3: SDI4
57	QDS	4K AUDIO INPUT SELECT DisplayPort	0: DisplayPort1 1: DisplayPort2
58	QHS	4K AUDIO INPUT SELECT HDMI	0: HDMI1 1: HDMI2
59	QBO	BLUE ONLY	0: OFF 1: ON
60	QBM	BLACK MODE	0: OFF 1: ON
61	QRC	R COLOR	0: OFF 1: ON
62	QGC	G COLOR	0: OFF 1: ON
63	QBC	B COLOR	0: OFF 1: ON
64	QDP	SDI DISPLAY MODE	0: SINGLE 1: QUAD
65	QPP	PIXEL TO PIXEL	0: OFF 1: ON
66	QDT	DISPLAY SELECT	[For QUAD] 0: SDI1 1: SDI2 2: SDI3 3: SDI4 [For PICTURE ASSIST] 1: AREA2 2: AREA3 3: AREA4
67	QMF	MULTI FUNCTION	0: OFF 1: ON
68	QPA	PICTURE ASSIST	0: OFF 1: ON
69	QMT	AUDIO MUTE	0: OFF 1: ON
70	QLM	LEVEL METER	0: OFF 1: 2ch 2: 4ch 3: 8ch

(Continued on next page)

## REMOTE Specifications (Continued)

No.	Command parameter	Description	Response data
71	QTM	TIME CODE	0: OFF      1: LTC      2: VTC      3: LUB      4: VUB 5: LTC+LUB   6: VTC+VUB
72	QCC* <sup>3</sup>	CLOSED CAPTION	00: OFF 05: SRV1(CEA-708) 06: SRV2(CEA-708)      07: SRV3(CEA-708) 08: SRV4(CEA-708)      09: SRV5(CEA-708) 10: SRV6(CEA-708)      12: OP-47 17: CC1(CEA-608(708))      18: CC2(CEA-608(708)) 19: CC3(CEA-608(708))      20: CC4(CEA-608(708))
73	QF1	FRAME MARKER	0: OFF      1: ON
74	QFO	OUTER LINE MARKER	0: OFF      1: ON
75	QSV	SCREEN SAVER	0: OFF      1: ON
76	QFR	FORMAT CHECK	00: NO SIGNAL 01: 1920x1080/60i, 1920x1080/30PsF 02: 1920x1080/59.94i, 1920x1080/29.97PsF 03: 1920x1080/50i, 1920x1080/25PsF 04: 1920x1080/30p      05: 1920x1080/29.97p 06: 1920x1080/25p      07: 1920x1080/24p 08: 1920x1080/23.98p      09: 1920x1080/24PsF 10: 1920x1080/23.98PsF      13: 1280x720/60p 14: 1280x720/59.94p      20: 1920x1080/60p 21: 1920x1080/59.94p      22: 1920x1080/50p 23: 1280x720/50p      24: 2048x1080/30PsF 25: 2048x1080/29.97PsF      26: 2048x1080/25PsF 27: 2048x1080/24PsF      28: 2048x1080/23.98PsF 29: 2048x1080/25p      30: 2048x1080/24p 31: 2048x1080/23.98p      32: 3840x2160/60p 33: 3840x2160/59.94p      34: 3840x2160/50p 35: 3840x2160/30p      36: 3840x2160/29.97p 37: 3840x2160/25p      38: 3840x2160/24p 39: 3840x2160/23.98p      40: 4096x2160/60p 41: 4096x2160/59.94p      42: 4096x2160/25p 43: 4096x2160/24p      44: 4096x2160/23.98p 51: 640x480      54: 800x600 57: 1024x768      61: 1280x768 63: 1280x1024      71: 1280x800 66: 1600x1200      67: 1920x1200  FF: UNSUPPORT SIGNAL
77	QID	MODEL CHECK	BT-4LH310

\*<sup>3</sup> Responds with the setting states of the CLOSED CAPTION, CC TYPE, CAPTION CHANNEL, CAPTION SERVICE menu items of DISPLAY SETUP.

# Error and Warning Information

---

If for any reason an error occurs in the unit, the following is displayed to notify of the error or warning.

Error/warning	Symptom	Remedy
<b>Warning of drop in external DC input voltage/ LOW VOLTAGE</b>	The [LOW VOLTAGE] indication in blue flashes on the screen. This means that the external DC power supply input voltage has dropped to less than approximately 22.0 V.	When the unit is powered down, connect an external DC power supply providing 23.4 V or more and then turn the POWER switch on.
	The [LOW VOLTAGE] indication lights red on the screen and the power is turned off approximately 10 seconds later. This means that the external DC power supply input voltage has dropped below approximately 21.5 V.	

## Cleaning

---

- Gently wipe off any dirt on the cabinet and LCD panel with a soft cloth. To remove stubborn dirt, use a cloth that has been dampened in a weak neutral detergent solution and thoroughly wrung out and then wipe the unit with a dry cloth. Any moisture entering the unit may damage it.
- Never use alcohol, benzene, thinner, chemically-treated cloth, etc. to clean the unit.  
The surface may become discolored and the paint may peel off.
- Do not directly expose the unit to spray cleaner or the like. Any moisture entering the unit could damage it.

# Specifications

---

## ■ General

### Power input

Power supply voltage	Current consumption
AC: 100 - 240 V, 50/60 Hz	1.71 A - 0.67 A
DC: 28 V (23.4 - 30 V)	4.59 A

 indicates safety information.

Dimensions (W x H x D):	758 mm × 495 mm × 258 mm (29-13/16" × 19-1/2" × 10-3/16") (including stand) 758 mm × 474 mm × 132 mm (29-13/16" × 18-5/8" × 5-3/16") (unit only, not including stand)
Weight:	20.0 kg (44.1 lbs) (including stand) 18.5 kg (40.8 lbs) (unit only, not including stand)
Operating temperature range:	5 °C to 35 °C (41 °F to 95 °F) (up to 2 000 m(6561' 1/8") above sea level)
Operating humidity range:	20% to 80% (non-condensing)
Storage temperature:	-20 °C to 60 °C (-4 °F to 140 °F)

## ■ Display panel

Dimensions:	78.9 cm (31.1") (effective display area)
Aspect ratio:	17:9
Number of pixels:	4096 × 2160
Display colors:	Approx. 1 000 000 000
Viewing angle (contrast > 10:1):	178 degrees left/right, 178 degrees up/down

## ■ Connectors

SDI inputs:	BNC x 4 SMPTE ST 424 / 425-1 / 274 / 296 compliant EMBEDDED AUDIO supported 3G-SDI: SMPTE ST 299 compliant 48 kHz, synchronous supported 16 channels supported HD-SDI: SMPTE ST 299 compliant 48 kHz, synchronous supported 8 channels supported
HDMI:	HDMI connector x 2 (Type A) HDCP supported EMBEDDED AUDIO supported VIERA Link not supported
DisplayPort input:	DisplayPort connector x 2 HDCP supported EMBEDDED AUDIO supported
SDI output (active through-out):	BNC x 4
GPI:	D-SUB, 9-pin x 1
RS232C:	D-SUB, 9-pin x 1
RS485:	RJ-45 x 2 (input and output)
Headphones:	Stereo mini jack M3 x 1, 32 Ω, level adjustable

## ■ Other connectors

Speaker output:	Monaural 0.5 W
Tally output (display):	Red, green, and amber



## Specifications (Continued)

### ■ List of supported SDI input signal formats

Categories					
SINGLE / QUAD	4:2:2 / 4:4:4	YCbCr / RGB / XYZ	8 / 10 / 12bit	HD / 3G	Input signal format/ status display
SINGLE	4:2:2	YCbCr	8 / 10	HD	1280x720/50p
	4:4:4	YCbCr / RGB	8 / 10	3G	
SINGLE	4:2:2	YCbCr	8 / 10	HD	1280x720/60p*1
	4:4:4	YCbCr / RGB	8 / 10	3G	
SINGLE	4:2:2	YCbCr	8 / 10	HD	1920x1035/60i*1*4
SINGLE	4:2:2	YCbCr	8 / 10	HD	1920x1080/ 24PsF*1
	4:2:2	YCbCr / RGB	12	3G*2	
	4:4:4	YCbCr / RGB	8 / 10 / 12		
SINGLE	4:2:2	YCbCr	8 / 10	HD	1920x1080/ 25PsF*5
	4:2:2	YCbCr	12	3G	
	4:4:4	YCbCr / RGB	8 / 10 / 12		
SINGLE	4:2:2	YCbCr	8 / 10	HD	1920x1080/ 30PsF*1*5
	4:2:2	YCbCr	12	3G	
	4:4:4	YCbCr / RGB	8 / 10 / 12		
SINGLE	4:2:2	YCbCr	8 / 10	HD	1920x1080/50i
	4:2:2	YCbCr	12	3G	
	4:4:4	YCbCr / RGB	8 / 10 / 12		
SINGLE	4:2:2	YCbCr	8 / 10	HD	1920x1080/60i*1
	4:2:2	YCbCr	12	3G	
	4:4:4	YCbCr / RGB	8 / 10 / 12		
SINGLE	4:2:2	YCbCr	8 / 10	HD	1920x1080/24p*1
	4:2:2	YCbCr	12	3G	
	4:4:4	YCbCr / RGB	8 / 10 / 12		
SINGLE	4:2:2	YCbCr	8 / 10	HD	1920x1080/25p
	4:2:2	YCbCr	12	3G	
	4:4:4	YCbCr / RGB	8 / 10 / 12		
SINGLE	4:2:2	YCbCr	8 / 10	HD	1920x1080/30p*1
	4:2:2	YCbCr	12	3G	
	4:4:4	YCbCr / RGB	8 / 10 / 12		
SINGLE	4:2:2	YCbCr	8 / 10	3G	1920x1080/50p
SINGLE	4:2:2	YCbCr	8 / 10	3G	1920x1080/60p*1
SINGLE*3	4:2:2	YCbCr	12	3G	2048x1080/ 24PsF*1
	4:4:4	YCbCr / RGB / XYZ	8 / 10 / 12		
SINGLE*3	4:2:2	YCbCr	12	3G	2048x1080/ 25PsF
	4:4:4	YCbCr / RGB / XYZ	8 / 10 / 12		
SINGLE*3	4:2:2	YCbCr	12	3G	2048x1080/ 30PsF*1
	4:4:4	YCbCr / RGB / XYZ	8 / 10 / 12		

\*1 The frame frequency of 1/1.001 is also supported.

\*2 Only LEVEL B-DL is supported for audio.

\*3 Audio is not supported.

\*4 The status display of 1920x1035/60i is displayed as 1920x1080/60i.

\*5 The status displays of 1920x1080/25PsF and 1920x1080/30PsF are displayed as 1920x1080/50i and 1920x1080/60i, respectively.

## Specifications (Continued)

Categories					
SINGLE / QUAD	4:2:2 / 4:4:4	YCbCr / RGB / XYZ	8 / 10 / 12bit	HD / 3G	Input signal format/ status display
SINGLE*3	4:2:2	YCbCr	8 / 10	HD	2048x1080/24p*1
	4:2:2	YCbCr	12	3G	
	4:4:4	YCbCr / RGB / XYZ	8 / 10 / 12		
SINGLE*3	4:2:2	YCbCr	8 / 10	HD	2048x1080/25p
	4:2:2	YCbCr	12	3G	
	4:4:4	YCbCr / RGB / XYZ	8 / 10 / 12		
QUAD*6*7	4:2:2	YCbCr	8 / 10	HD	3840x2160/24p*1
	4:2:2	YCbCr	12	3G	
	4:4:4	YCbCr / RGB	8 / 10 / 12		
QUAD*6*7	4:2:2	YCbCr	8 / 10	HD	3840x2160/25p
	4:2:2	YCbCr	12	3G	
	4:4:4	YCbCr / RGB	8 / 10 / 12		
QUAD*6*7	4:2:2	YCbCr	8 / 10	HD	3840x2160/30p*1
	4:2:2	YCbCr	12	3G	
	4:4:4	YCbCr / RGB	8 / 10 / 12		
QUAD*6*7	4:2:2	YCbCr	8 / 10	3G	3840x2160/50p
QUAD*6*7	4:2:2	YCbCr	8 / 10	3G	3840x2160/60p*1
QUAD*3*6*7	4:2:2	YCbCr	8 / 10	HD	4096x2160/24p*1
	4:2:2	YCbCr	12	3G	
	4:4:4	YCbCr / RGB	8 / 10 / 12		
	4:4:4	XYZ	12		
QUAD*3*6*7	4:2:2	YCbCr	8 / 10	HD	4096x2160/25p
	4:2:2	YCbCr	12	3G	
	4:4:4	YCbCr / RGB	8 / 10 / 12		
	4:4:4	XYZ	12		
QUAD*3*6*7	4:2:2	YCbCr	8 / 10	HD	4096x2160/30p*1
	4:2:2	YCbCr	12	3G	
	4:4:4	YCbCr / RGB	8 / 10 / 12		
	4:4:4	XYZ	12		
QUAD*3*6*7	4:2:2	YCbCr	8 / 10	3G	4096x2160/50p
QUAD*3*6*7	4:2:2	YCbCr	8 / 10	3G	4096x2160/60p*1

\*1 The frame frequency of 1/1.001 is also supported.

\*3 Audio is not supported.

\*6 Square Division is supported.

\*7 If the SDI1 input connector is disconnected and connected, all of the screens may be become momentarily distorted.

## Specifications (Continued)

### ■ List of supported HDMI and DisplayPort input video signal formats (✓: supported format)

Categories						
SINGLE / DUAL	4:2:2 / 4:4:4	YCbCr / RGB	8 / 10 / 12bit	Input signal format/ Status display	HDMI	DisplayPort
SINGLE	4:4:4	YCbCr / RGB	8 / 10	720x480/60p*1	✓	
	4:4:4	YCbCr / RGB	12		✓	
	4:2:2	YCbCr	8 / 12		✓	
SINGLE	4:4:4	YCbCr / RGB	8 / 10	720x576/50p	✓	
	4:4:4	YCbCr / RGB	12		✓	
	4:2:2	YCbCr	8 / 12		✓	
SINGLE	4:4:4	YCbCr / RGB	8 / 10	1280x720/50p	✓	✓
	4:4:4	YCbCr / RGB	12		✓	
	4:2:2	YCbCr	8 / 12		✓	
SINGLE	4:4:4	YCbCr / RGB	8 / 10	1280x720/60p*1	✓	✓
	4:4:4	YCbCr / RGB	12		✓	
	4:2:2	YCbCr	8 / 12		✓	
SINGLE	4:4:4	YCbCr / RGB	8 / 10	1920x1080/50i	✓	✓
	4:4:4	YCbCr / RGB	12		✓	
	4:2:2	YCbCr	8 / 12		✓	
SINGLE	4:4:4	YCbCr / RGB	8 / 10	1920x1080/60i*1	✓	✓
	4:4:4	YCbCr / RGB	12		✓	
	4:2:2	YCbCr	8 / 12		✓	
SINGLE	4:4:4	YCbCr / RGB	8 / 10	1920x1080/24p*1	✓	✓
	4:4:4	YCbCr / RGB	12		✓	
	4:2:2	YCbCr	8 / 12		✓	
SINGLE	4:4:4	YCbCr / RGB	8 / 10	1920x1080/25p	✓	✓
	4:4:4	YCbCr / RGB	12		✓	
	4:2:2	YCbCr	8 / 12		✓	
SINGLE	4:4:4	YCbCr / RGB	8 / 10	1920x1080/30p*1	✓	✓
	4:4:4	YCbCr / RGB	12		✓	
	4:2:2	YCbCr	8 / 12		✓	
SINGLE	4:4:4	YCbCr / RGB	8 / 10	1920x1080/50p	✓	✓
	4:4:4	YCbCr / RGB	12		✓	
	4:2:2	YCbCr	8 / 12		✓	
SINGLE	4:4:4	YCbCr / RGB	8 / 10	1920x1080/60p*1	✓	✓
	4:4:4	YCbCr / RGB	12		✓	
	4:2:2	YCbCr	8 / 12		✓	
SINGLE	4:4:4	YCbCr / RGB	8 / 10	2048x1080/24p*1	✓	✓
	4:4:4	YCbCr / RGB	12		✓	
	4:2:2	YCbCr	8 / 12		✓	
SINGLE	4:4:4	YCbCr / RGB	8 / 10	2048x1080/25p	✓	✓
	4:4:4	YCbCr / RGB	12		✓	
	4:2:2	YCbCr	8 / 12		✓	

\*1 The frame frequency of 1/1.001 is also supported.

## Specifications (Continued)

Categories						
SINGLE / DUAL	4:2:2 / 4:4:4	YCbCr / RGB	8 / 10 / 12bit	Input signal format/ Status display	HDMI	DisplayPort
SINGLE	4:4:4	YCbCr / RGB	8	3840x2160/24p*1	✓	✓
	4:4:4	YCbCr / RGB	10			✓
	4:2:2	YCbCr	8 / 12		✓	
SINGLE	4:4:4	YCbCr / RGB	8	3840x2160/25p	✓	✓
	4:4:4	YCbCr / RGB	10			✓
	4:2:2	YCbCr	8 / 12		✓	
SINGLE	4:4:4	YCbCr / RGB	8	3840x2160/30p*1	✓	✓
	4:4:4	YCbCr / RGB	10			✓
	4:2:2	YCbCr	8 / 12		✓	
DUAL*2*3	4:4:4	YCbCr / RGB	8	3840x2160/50p	✓	✓
	4:4:4	YCbCr / RGB	10			✓
	4:2:2	YCbCr	8 / 12		✓	
DUAL*2*3	4:4:4	YCbCr / RGB	8	3840x2160/60p*1	✓	✓
	4:4:4	YCbCr / RGB	10			✓
	4:2:2	YCbCr	8 / 12		✓	
SINGLE	4:4:4	YCbCr / RGB	8	4096x2160/24p*1	✓	✓
	4:4:4	YCbCr / RGB	10			✓
	4:2:2	YCbCr	8 / 12		✓	
DUAL*2*3	4:4:4	YCbCr / RGB	8	4096x2160/50p	✓	✓
	4:4:4	YCbCr / RGB	10			✓
	4:2:2	YCbCr	8 / 12		✓	
DUAL*2*3	4:4:4	YCbCr / RGB	8	4096x2160/60p*1	✓	✓
	4:4:4	YCbCr / RGB	10			✓
	4:2:2	YCbCr	8 / 12		✓	

\*1 The frame frequency of 1/1.001 is also supported.

\*2 In the case of DUAL, it is necessary to input signals with the same resolution and frame frequency, and vertical synchronization timing that matches.

\*3 If the HDMI signal input connector and DisplayPort1 signal input connector are disconnected and connected, all of the screens may be become momentarily distorted.

## Specifications (Continued)

### ■ List of supported HDMI and DisplayPort input PC signal formats (✓: supported format)

Categories						
SINGLE / DUAL	4:2:2 / 4:4:4	YCbCr / RGB	8 / 10 / 12bit	Input signal format/ Status display	HDMI	DisplayPort
SINGLE	4:4:4	RGB	8	640x480* <sup>6</sup>	✓	✓
	4:4:4	RGB	10		✓	
SINGLE	4:4:4	RGB	8	800x600* <sup>6</sup>	✓	✓
	4:4:4	RGB	10		✓	
SINGLE	4:4:4	RGB	8	1024x768* <sup>6</sup>	✓	✓
	4:4:4	RGB	10		✓	
SINGLE	4:4:4	RGB	8	1280x768* <sup>6</sup>		✓
	4:4:4	RGB	10			✓
	4:4:4	RGB	8	1280x800* <sup>6</sup>		✓
	4:4:4	RGB	10			✓
	4:4:4	RGB	8	1280x1024* <sup>6</sup>	✓	✓
	4:4:4	RGB	10			✓
SINGLE	4:4:4	RGB	8	1600x1200* <sup>6</sup>		✓
	4:4:4	RGB	10			✓
SINGLE	4:4:4	RGB	8	1920x1080/60p* <sup>1*4*5</sup>	✓	✓
	4:4:4	RGB	10			✓
	4:4:4	RGB	8	1920x1200* <sup>7</sup>		✓
	4:4:4	RGB	10			✓
SINGLE	4:4:4	RGB	8	3840x2160/24p* <sup>1*4</sup>	✓	✓
	4:4:4	RGB	10			✓
	4:4:4	RGB	8	3840x2160/25p* <sup>4</sup>	✓	✓
	4:4:4	RGB	10			✓
DUAL * <sup>2*3</sup>	4:4:4	RGB	8	3840x2160/50p* <sup>4</sup>	✓	✓
	4:4:4	RGB	10			✓
DUAL * <sup>2*3</sup>	4:4:4	RGB	8	3840x2160/60p* <sup>1*4</sup>	✓	✓
	4:4:4	RGB	10			✓
SINGLE	4:4:4	RGB	8	4096x2160/24p* <sup>1*4</sup>	✓	✓
	4:4:4	RGB	10			✓
DUAL * <sup>2*3</sup>	4:4:4	RGB	8	4096x2160/60p* <sup>1*4</sup>	✓	✓
	4:4:4	RGB	10			✓

\*<sup>1</sup> The frame frequency of 1/1.001 is also supported.

\*<sup>2</sup> In the case of DUAL, it is necessary to input signals with the same resolution and frame frequency, and vertical synchronization timing that matches.

\*<sup>3</sup> If the HDMI signal input connector and DisplayPort1 signal input connector are disconnected and connected, all of the screens may be become momentarily distorted.

\*<sup>4</sup> Displayed as a video signal.

\*<sup>5</sup> CEA-861-D

\*<sup>6</sup> VESA DMT

Only 60 Hz is supported for the frame frequency.

\*<sup>7</sup> VESA DMT Reduced Blanking

Only 60 Hz is supported for the frame frequency.

#### <Note>

The RGB and YCbCr formats and 8-bit, 10-bit, and 12-bit are switched automatically according to the input signal.

## Specifications (Continued)

---

### ■ Closed caption decoding

#### Supported signals

<b>HD-SDI</b>	1080/60i*1, 1080/50i, 720/60p*1, 1080/24PsF*1, 1080/30p*1, 1080/24p*1
---------------	---

#### Supported standards

<b>HD-SDI</b>	EIA/CEA-608 (708), EIA/CEA-708, OP47
---------------	--------------------------------------

#### Supported specifications (EIA/CEA-608)

<b>Decode channels</b>	CC1 to CC4*2
<b>Character</b>	Standard Character, Special Character

#### Supported specifications (EIA/CEA-708)

<b>Caption service</b>	Service #1 to #6
<b>Character</b>	G0 Code, G1 Code, Window Style*3, Pen Style*4

\*1 The frame frequency of 1/1.001 is also supported.

\*2 The XDS service is not supported

\*3 Window Style

Only justify LEFT is supported.

Only print direction LEFT-TO-RIGHT is supported.

Only scroll direction BOTTOM-TO-TOP is supported.

Word wrap is not supported.

Only the display effect SNAP is supported.

Fill color is not supported.

Fill opacity is not supported.

Border type is not supported.

\*4 Pen Style

Pen size SMALL is supported.

Font style is 0

Only offset NORMAL is supported.

Italics is supported.

Underline is supported.

Only edge type UNIFORM is supported.

Foreground colors: white, blue, green, yellow, cyan, red, gray, and magenta are supported.

Foreground opacity is not supported.

Background colors: black and orange (orange is displayed when any color other than black is specified) are supported.

Background opacity: only black (semi-transparent) is supported.

#### <Note>

- 3G-SDI signals are not supported.

**Specifications (Continued)**

■ INT-SG (Internal chart for adjustment)

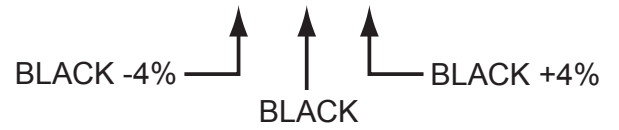
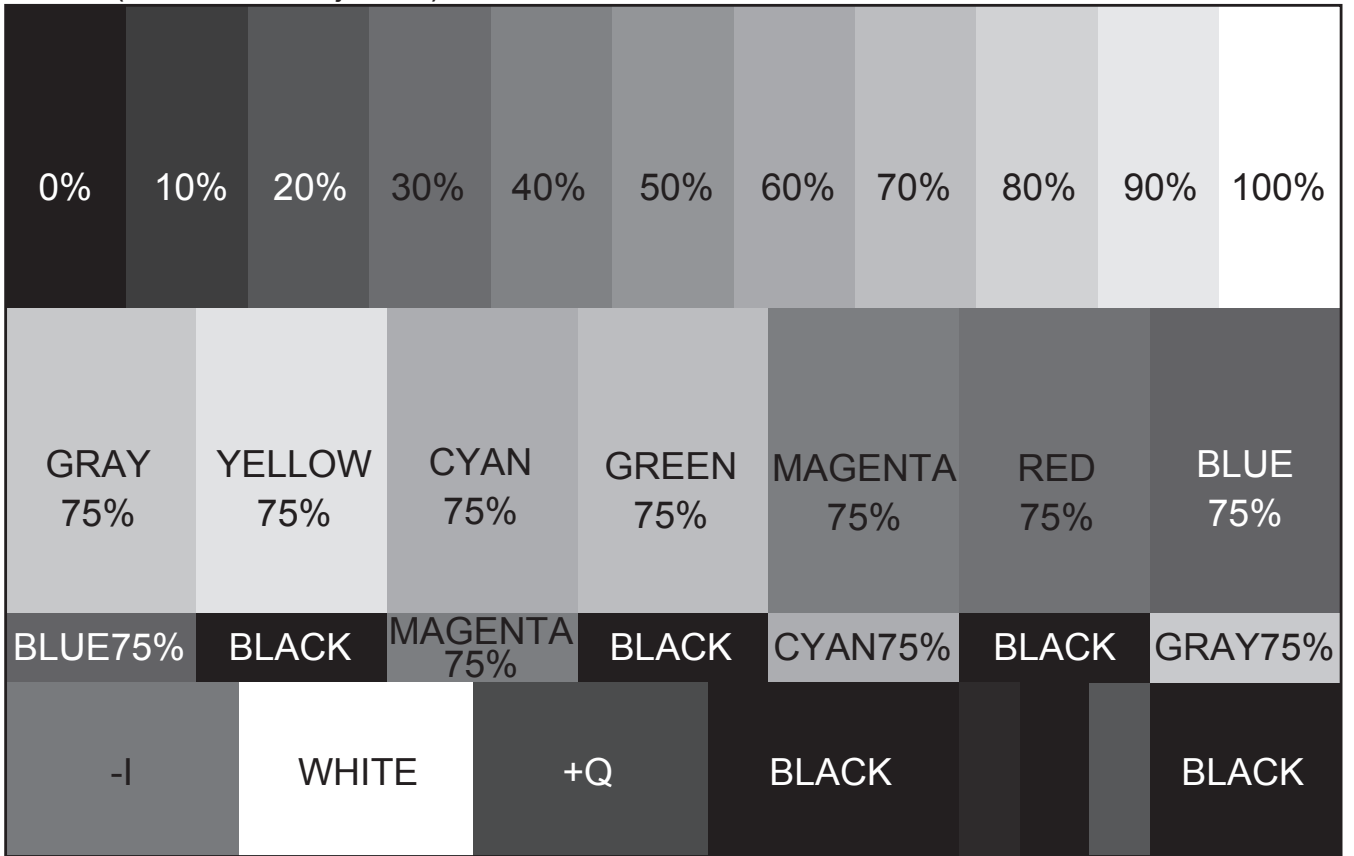

# Utility Software (Support Coming Soon)

## ■ User customization function

Utility software that supports this function is available from the Panasonic website. For details, see the Panasonic website (<http://pro-av.panasonic.net>). This software allows you to write to the user areas in FilmGamma and ColorSpace and perform calibration adjustments.

### ● FilmGamma upload

When the unit settings are set as follows, user defined values will be set.

The underlined values are the factory defaults.

Submenu	Setting	Description
<b>GAMMA SELECT</b>	FILM	Selects the gamma curve. [FILM] Film mode • When [FILM] is selected, the <b>FILM</b> mark is displayed for the operating status.
<b>FILM GAMMA</b>	<u>VARICAM</u> OTHER USER1-3	Selects the FILM gamma mode type. [VARICAM] For VARICAM use [OTHER] For other cameras [USER1/USER2/USER3] User download items

Three user defined values can be registered as shown below.

To register user defined values, use the FilmGammaSoftware utility software.

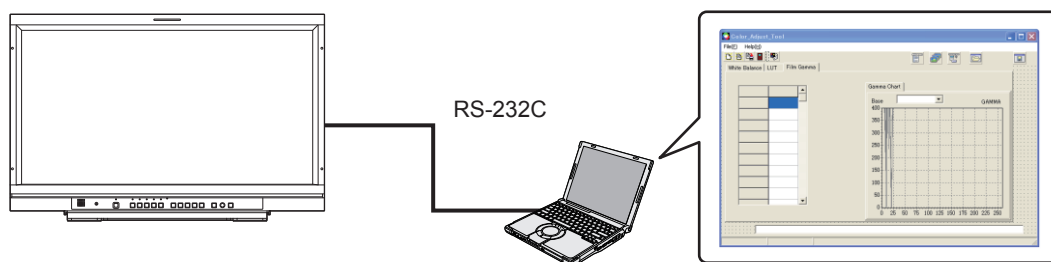

For how to install and operate the software, refer to the operating instructions of the software.

### ● LUT upload

User defined values can be set when setting the following settings.

Submenu	Setting	Description
<b>LUT</b>	USER1-3	Reproduces colors in accordance with the set COLOR SPACE using the 3D LUT (look up table). [USER1/USER2/USER3] Allows you to select a user setting value.

Three user defined values can be registered as shown below.

To register user defined values, use the LUTSoftware utility software.

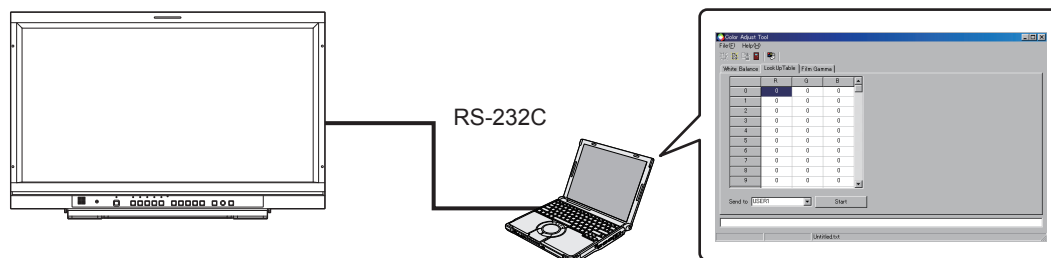

For how to install and operate the software, refer to the operating instructions of the software.



## Utility Software (Support Coming Soon) (Continued)

### • Calibration adjustments

The unit can be calibrated by directly connecting an analyzer (CA-310) and via a PC for managing calibration data. For how to calibrate the unit by directly connecting an analyzer (CA-310), refer to "CALIBRATION" (→ page 35). The following describes how to calibrate the unit via a PC.

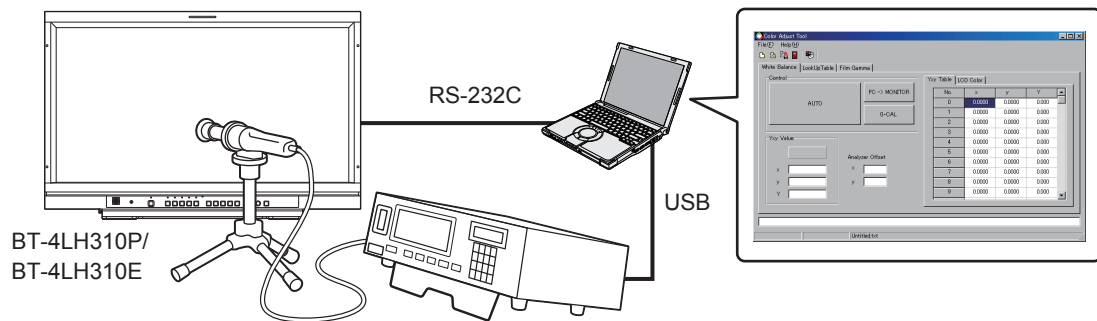

(Supported analyzers)

Konica Minolta: CA-210/CA-310 Display Color Analyzer

X-Rite: i1 Pro Standard Measurement Probe

PHOTO RESEARCH: PR-655

For how to install and operate the software, refer to the operating instructions of the software.

# Index

## Numerics

2K/HD MODE .....	31
4K INPUT SELECT .....	46
4K MODE .....	31
1080i/PsF .....	31

## A

Accessories .....	7
AREA1 .....	24
AREA2 .....	25
ASPECT1 .....	24
ASPECT1 MODE(16:9) .....	24
ASPECT1 MODE(17:9) .....	24
ASPECT1 RATIO .....	24
ASPECT2 .....	24
ASPECT2 MODE(16:9) .....	25
ASPECT2 MODE(17:9) .....	25
ASPECT2 RATIO .....	24
AUDIO .....	46
Audio level meter .....	18
AUDIO LEVEL METER .....	47
Audio volume .....	17, 21
AUTO CALIBRATION .....	35, 36

## B

BACK .....	25
BACKLIGHT .....	21
BIAS .....	29
BRIGHT .....	21

## C

CALIBRATION .....	33, 35
CAPTION CHANNEL .....	47
CAPTION SERVICE .....	47
CC TYPE .....	47
CENTER .....	25
Center marker .....	27
CH INFO. ....	47
CHROMA .....	21
CH SELECT .....	47
Cleaning .....	63
CLOSED CAPTION .....	47
Closed captions .....	19, 70
COLOR .....	25, 30
COLOR GAIN .....	29
COLOR ITEM .....	25
COLOR SPACE .....	29
COLOR TEMP. ....	28
CONTRAST .....	21
CONTROL .....	48
CRCC ERROR .....	32
CROSS .....	25
CROSS HATCH .....	26, 45
Cross marker .....	27

## D

DC power supply .....	14
Dimensions .....	10
DisplayPort .....	46
DisplayPort connector .....	13, 67
DISPLAY SETUP .....	47

## E

Error .....	63
EXT. MAX. ....	30
EXT. MIN. ....	30

## F

FILM GAMMA .....	28
------------------	----

FOCUS-IN-RED .....	21, 30, 45
FORMAT .....	31
FRAME GRAB .....	29, 43
FUNCTION .....	17, 37
FUNCTION buttons .....	12, 39
FUNCTION DISPLAY .....	38
FUNCTION menu .....	16, 20
FUNCTION skip function .....	41

## G

GAIN .....	29
GAMMA SELECT .....	28
GPI .....	48
GPI CONTROL .....	48
GPI input connector .....	13, 54
GROUP SELECT .....	46

## H

HDMI .....	46
HDMI connector .....	13, 67
HEADPHONES output connector .....	12
HEAD ROOM .....	47
HOURS METER .....	49

## I

INFORMATION .....	49
INPUT NAME SETUP .....	32, 34
INPUT SELECT .....	16, 20
INPUT SELECT buttons .....	12
INT. MAX. ....	30
INT. MIN. ....	30
INT-SG .....	71

## L

LCD .....	49
LED BRIGHT .....	33
LINE SELECT .....	30
LOCAL ENABLE .....	48
LUT .....	29, 72

## M

Main menu .....	16, 20, 23
MAIN MENU .....	16, 20
MAIN MENU POSITION .....	32
MARKER .....	24
Type .....	27
MEASURE SETUP .....	30
Menu .....	
Configuration .....	23
Display .....	16
Operation .....	20
MENU button .....	12
MODE .....	30
MODE SELECT .....	47
MONO .....	29
MULTI FUNCTION .....	42

## O

Operating status display .....	16
OPERATION .....	49
Options .....	7

## P

PAYLOAD ID ERROR .....	32
PEAKING .....	21
PHASE .....	21
PICTURE .....	12
Picture adjustment menu .....	17, 21
PICTURE ASSIST .....	42
PICTURE menu .....	17, 21

## Index (Continued)

---

PIXEL TO PIXEL .....	45
POINT LINE .....	47
POSITION .....	29, 47
Power cable .....	14
POWER DOWN .....	33
POWER ON SETUP .....	32
POWER SAVE MODE .....	33
Power supply .....	14
POWER switch .....	12
Protective panel .....	7, 11

### R

RANGE .....	31
Recording Mark .....	33
REMOTE .....	54
RESET .....	29, 35, 36
RETURN button .....	12
Rotary knob .....	12
RS-232C input connector .....	13, 55
RS-485 ID SETUP .....	48
RS-485 input/output connectors .....	13, 56

### S

SCALE .....	30
SDI .....	46
SDI1 FORMAT .....	31
SDI2 FORMAT .....	31
SDI3 FORMAT .....	31
SDI4 FORMAT .....	32
SDI connector .....	13, 65
SDI DISPLAY MODE .....	31, 41
SDI ERROR .....	49
SDI REC TALLY .....	32
SELECT L .....	46
SELECT R .....	46
SETUP .....	38
SETUP LOAD .....	32
SETUP SAVE .....	32
SHARPNESS H .....	29
SHARPNESS MODE .....	29
SHARPNESS V .....	29
SIZE .....	26
Speaker .....	12
SPEAKER OUT .....	46
Specifications .....	64
Stand .....	15
STATUS DISPLAY .....	32
SYSTEM CONFIG .....	31

### T

Tally lamp .....	11
Time code .....	18
TIME CODE .....	47
Transportation precautions .....	7

### U

User data .....	22
-----------------	----

### V

VARnCOLOR TEMP. ....	28
VECTOR MODE .....	30
VIDEO CONFIG .....	28
VOLUME button .....	12

### W

Warning .....	63
WFM .....	30
WFM/VECTOR .....	43

### Y

Y MAP .....	30, 44
-------------	--------

### Z

ZEBRA .....	30, 44
ZOOM .....	43
ZOOM MODE .....	29
ZOOM POSITION .....	44

## Information on Disposal for Users of Waste Electrical & Electronic Equipment (private households)



This symbol on the products and/or accompanying documents means that used electrical and electronic products should not be mixed with general household waste. For proper treatment, recovery and recycling, please take these products to designated collection points, where they will be accepted on a free of charge basis. Alternatively, in some countries you may be able to return your products to your local retailer upon the purchase of an equivalent new product. Disposing of this product correctly will help to save valuable resources and prevent any potential negative effects on human health and the environment which could otherwise arise from inappropriate waste handling. Please contact your local authority for further details of your nearest designated collection point. Penalties may be applicable for incorrect disposal of this waste, in accordance with national legislation.

### For business users in the European Union

If you wish to discard electrical and electronic equipment, please contact your dealer or supplier for further information.

### Information on Disposal in other Countries outside the European Union

This symbol is only valid in the European Union.

If you wish to discard this product, please contact your local authorities or dealer and ask for the correct method of disposal.

## ENGLISH

### ■ How to open the operating instruction manual PDF files

Discontinue installation if the installation screen of the software opens as a result of inserting the CD-ROM.

When [INDEX.pdf] on the CD-ROM is opened, a list of the operating instruction manuals will be displayed.

Click on the document name of the manual to be opened.

### ■ Adobe® Reader® is required to read PDF files.

It can be downloaded from the home page of Adobe Systems.

## DEUTSCH

### ■ Öffnen der PDF-Dateien der Bedienungsanleitung

Brechen Sie die Installation ab, falls beim Einlegen der CD-ROM der Installationsbildschirm der Software erscheint.

Wenn [INDEX.pdf] auf der CD-ROM geöffnet wird, erscheint eine Liste der Bedienungsanleitungen.

Klicken Sie auf den Dokumentennamen der zu öffnenden Anleitung.

### ■ Zum Lesen der PDF-Dateien benötigen Sie Adobe® Reader®.

Dieses Programm kann von der Homepage von Adobe Systems heruntergeladen werden.

## FRANÇAIS

### ■ Comment ouvrir les fichiers PDF des manuels du mode d'emploi

Arrêter l'installation si l'écran d'installation du logiciel s'ouvre quand le CD-ROM est inséré.

Quand [INDEX.pdf] sur le CD-ROM s'ouvre, la liste des manuels du mode d'emploi s'affiche.

Cliquer sur le nom du document correspondant au manuel à consulter.

### ■ Adobe® Reader® est nécessaire pour lire les fichiers PDF.

Ce logiciel peut être téléchargé depuis la page d'accueil d'Adobe Systems.

## ITALIANO

### ■ Come aprire i file dei manuali di istruzioni per l'uso

Se inserendo il CD-ROM si apre la schermata di installazione del software, interrompere l'installazione.

Aprendo [INDEX.pdf] sul CD-ROM, viene visualizzato un elenco di manuali di istruzioni per l'uso.

Fare clic sul nome del documento corrispondente al manuale da aprire.

### ■ Per leggere i file PDF è necessario Adobe® Reader®.

Il programma può essere scaricato dal sito Web di Adobe Systems.

## ESPAÑOL

### ■ Modo de abrir los archivos PDF que contienen el manual de las instrucciones de funcionamiento

Interrumpa la instalación si la pantalla de instalación del software se abre como resultado de insertar el CD-ROM.

Cuando se abra [INDEX.pdf] en el CD-ROM se visualizara una lista de los manuales de instrucciones de funcionamiento.

Haga clic en el nombre de documento del manual que va a abrir.

### ■ Para leer los archivos PDF se necesita el programa Adobe® Reader®.

Este programa se puede descargar de la pagina inicial de Adobe Systems.